



Industrial Field Bus Standards Update (Physical Layer)

Bob Lounsbury
Principal Engineer
Rockwell Automation

Technical Track

www.odva.org

Standardization of cabling systems for communications networks has been ongoing since the early 90s. Since the initial standardization of industrial cabling systems for ODVA there have been many new high performance components and enhancements added. The standards organizations continue to work to provide standardization of these new components and systems. There are several national and international cabling standards that have a direct impact on networks throughout the world. These standards are either based on ODVA network standards and/or are the foundation for the ODVA networks.

This Presentation will focus on the current state of these standards and bring the audience up to date on how they affect ODVA.

Cabling Standards and Relationships

ISO/IEC/JTC 1/SC25/WG3
Information Technology Standards



SC65C/JWG10
Industrial Field Bus Standards



ANSI/TIA/TR42
Telecommunications Cabling Systems



ODVA
CIP



Cabling Standards Relationships

- **Three Categories of Standards for Cabling**
 - **Component Standards**
 - **Channel (Cabling) Definition Standards**
 - **Installation Standards**
- **Some Standards Bodies Combine the Component and Cabling Standards Together.**
- **Industrial Standards are Based on Generic Cabling Standards**

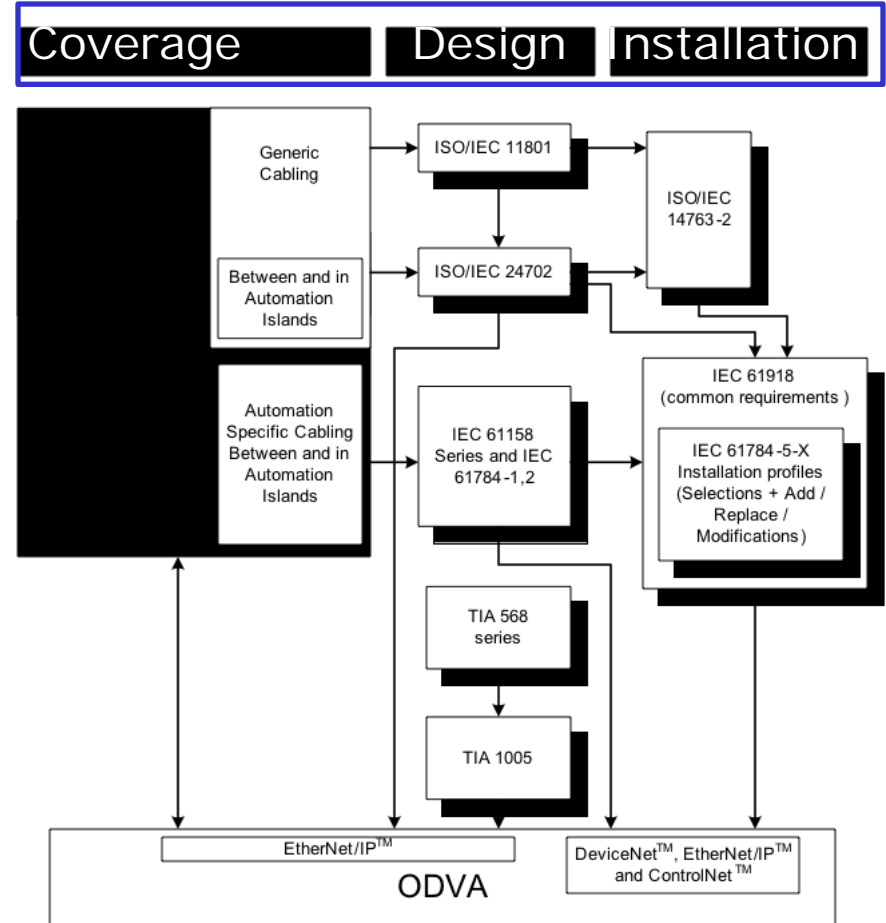

Standards Working Relationships

⑩ National and international standards work together through the US-TAGs and Liaisons.

⑩ Consortia work together through MOUs and cross licensing

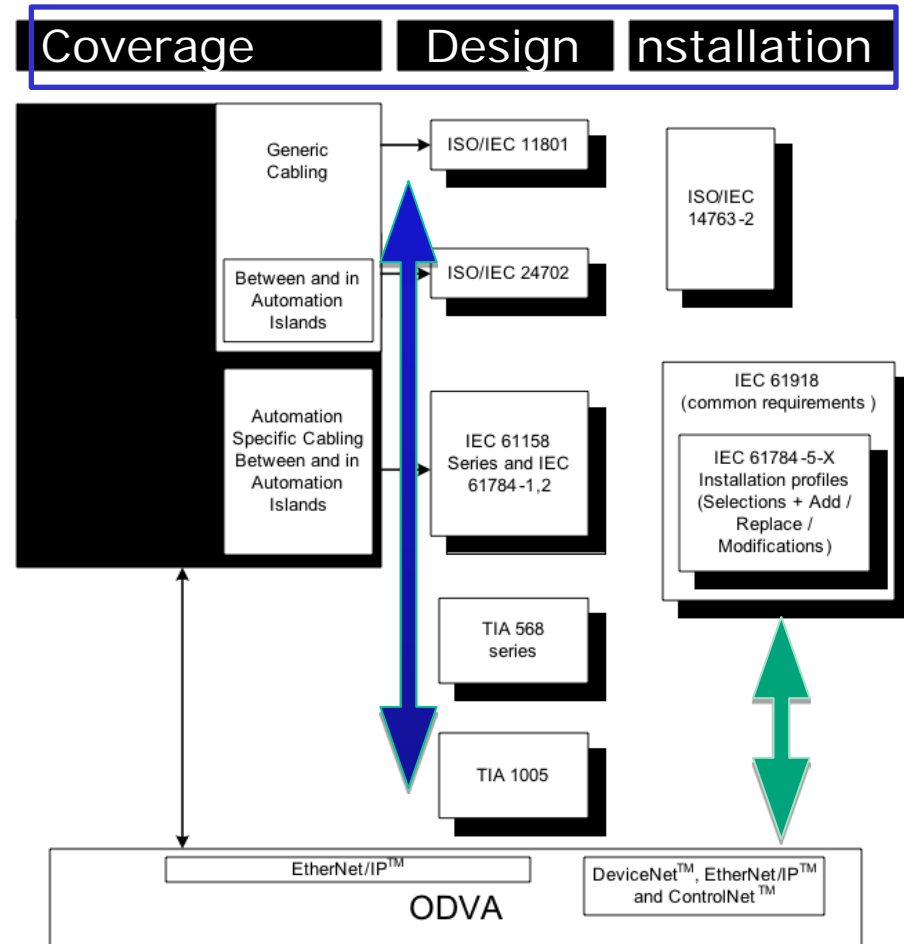

Standards Coverage Areas

⑩ Two Coverage areas

⑩ Office (commercial) Premises

Generic cabling mainly covers office spaces and general floor areas

⑩ Industrial Premises

Industrial cabling mainly covers in and between automation islands

⑩ The two overlap in some areas

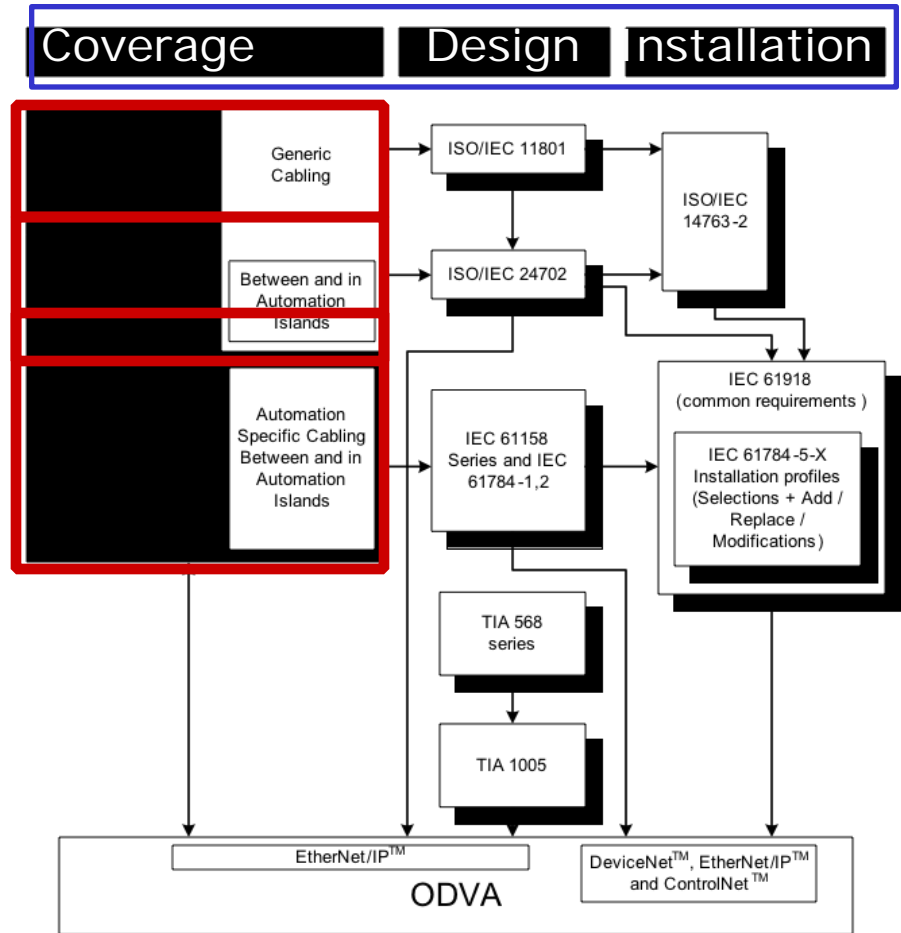

Cabling Specifications For Design

- ⑩ Five Cabling standards cover requirements for components and cabling systems

⑩ International Standards

ISO 11801
ISO/IEC 24702 (Industrial)
IEC 61158 and IEC 61784-1,2

⑩ Two National Standards

TIA 568-C,
TIA 569 & TIA 606B,
TIA 607B,
TIA 1005A

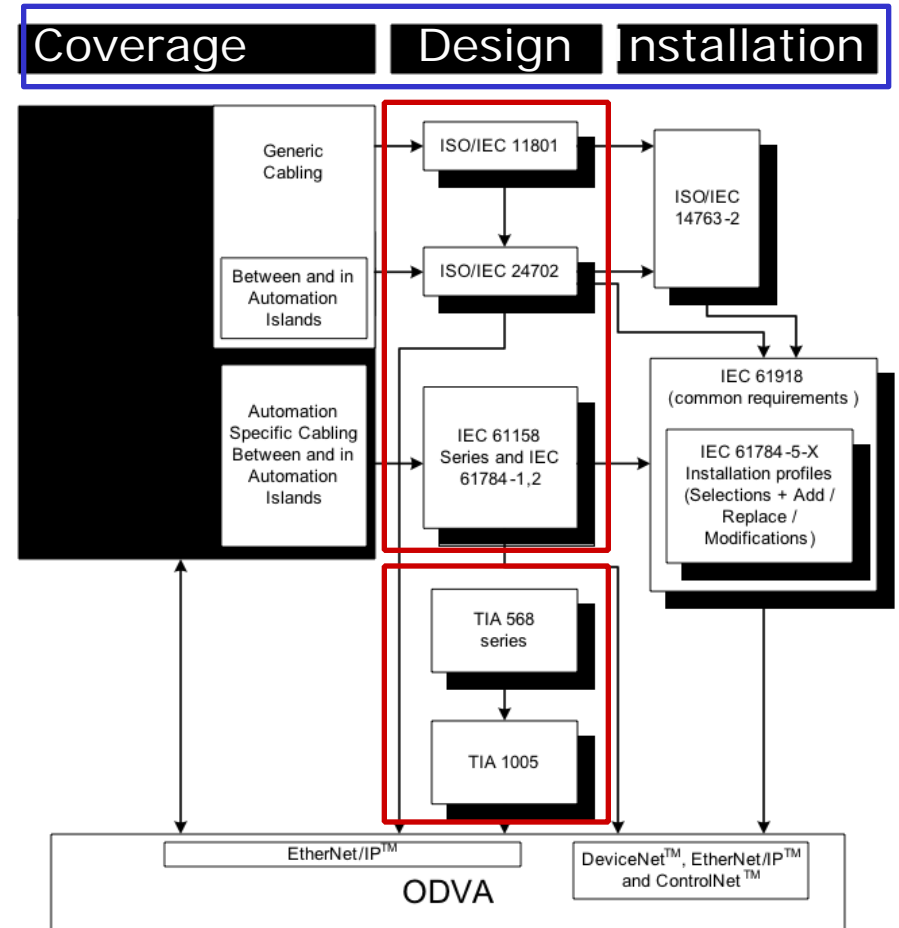



Cabling Installation

⑩ Installation has been primarily subject for the International Standards

⑩ ISO/IEC 14673 series written under ISO/IEC

Covers	
<i>Commercial</i>	<i>Residential</i>
<i>Data centers</i>	<i>Schools</i>
<i>Hospitals</i>	<i>Industrial</i>

⑩ IEC 61918 Ed3

⑩ IEC 61784-5-n written under IEC/SC65C/JWG10

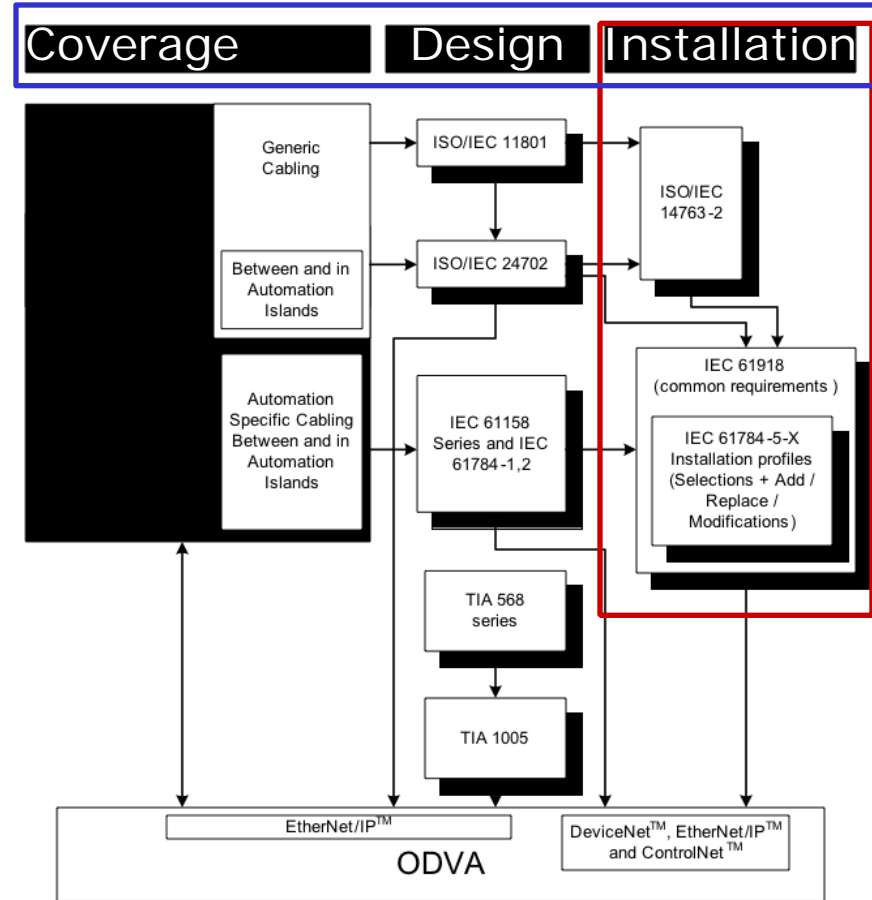

Closer Look at IEC 61784-5-2

- ⑩ Installation Profiles for;
 - ⑩ EtherNet/IP
 - ⑩ ControlNet
 - ⑩ DeviceNet
 - ⑩ Other Field Bus Networks

- ⑩ Eligible to be added in Maintenance cycle
 - ⑩ Entry of Competitor Networks
 - ⑩ Update of existing Networks
 - ⑩ After 2013 stable until 2018

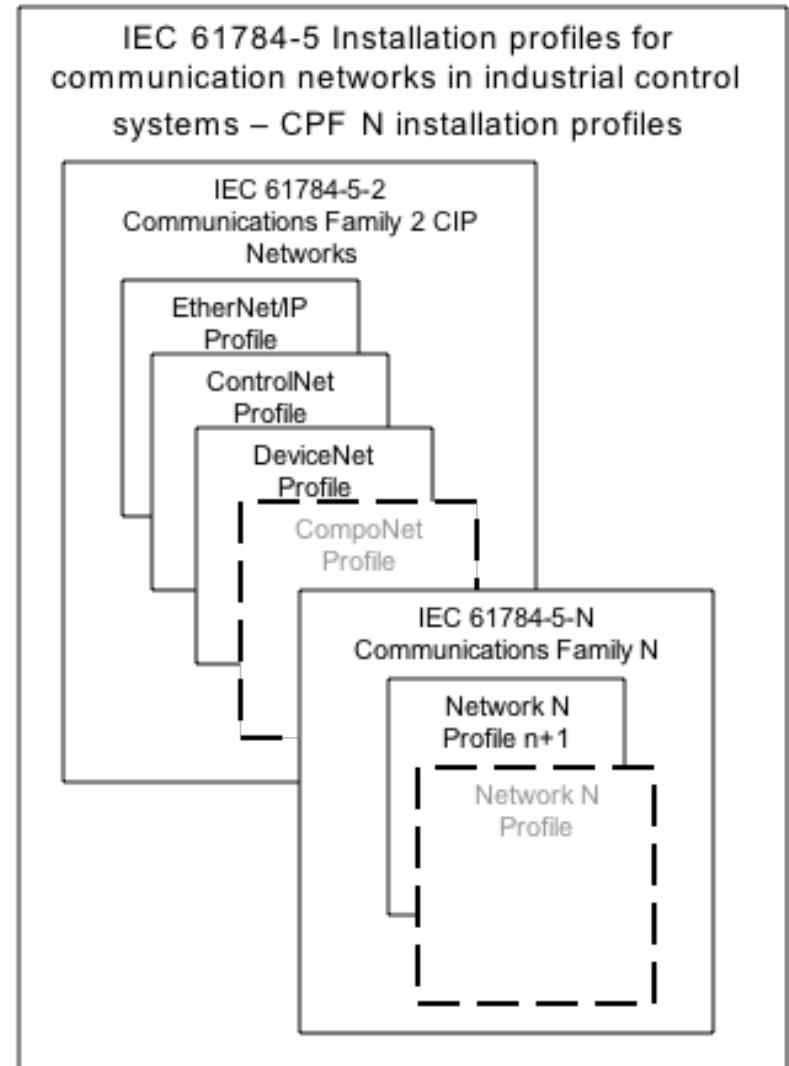

Installation Standards

IEC/SC65C/JWG10 Publishes Installation Standards for Field Bus Networks.

- IEC 61784-5-n Ed3 (most)
- IEC 61918 Ed3
- This Set of Standards is Stable Until 2018
- Tracking E2E Link
- Mixed Cables
- 1Gig Cabling

Closer Look at Cabling Standards

National

ANSI TIA TR42

International

ISO/IEC/JTC1/SC25/WG3

ISO/IEC/JTC1/SC25/WG3

Cabling and Component Standard

- **Restructuring ISO/IEC 11801 3rd edition**
- **Incorporating ISO/IEC 24702 into 11801**
- **JMTG working on E2E Link (more later)**
- **Earthing and Bonding**

Sub Group TR42.9 (Industrial)

- **Standard TIA1005A Industrial Premises Cabling**
- **Stable standard.**
- **SG working on Three Projects**
 - Addition of M12-8 X coded
 - Definition and addition of 1Gig Cabling
 - End to End Link

Sub Group TR 42.16

- **Grounding and Bonding**
- **ANSI TIA 607B**
- **Primary focus on Office Buildings and Antenna Farms**
- **Currently Under Revision**
- **SIG members Working with this Group for Harmonization Purposes.**

Close Look at IEEE 802.3 Projects

Active Projects

- **IEEE802.3bp** Single Pair Gigabit Ethernet PHY
- **IEEE802.3bt** defining 4-pair PoE with up to 100W at PD
- **IEEE802.3bu** defining 1-pair Power over Data Link

Other Projects Coming

- **100 Mb/s Over Single Pair**
- **1 Gigabit over POF**

IEEE 802.3bp RTPGE

- **Defining 1 pair 1000Base-T for the Automotive Industry and Industrial Automation Networks**
- **802.3bp PHY to be Known as 1000BASE-T1**
- **802.3bp Baseline Draft being Prepared for Review**
- **PoE Being Defined Separately for 1-Pair Data Lines PoDL**

IEEE 802.3bp Continued

- Full Duplex
- IEEE 802.3 Ethernet Frame Format
- IEEE 802.3 Ethernet Frame Length min/max
- $BER \leq 10^{-12}$
- 1G Operation at the MAC/PLS
- 15Meter Length
- ≥ 40 Meter Length Industrial

IEEE 802.3bt 4-Pr PoE up to 100W

- **TF Approved Nov 2013, Initial Meeting Held in January**
- **Defining 4-pair PoE with Higher Power Levels than 802.3at PoE+**
- **Interest in Achieving 100W Power Deliver at the PD**
- **Comply to the Limited Power Source & SELV Requirements Defined in ISO/IEC 60950**

IEEE 802.3bt Project PoE++

- **Support up to 10GBASE-T**
- **Support a Minimum of 49 Watts at the PD**
- **Define pair-to-pair Imbalance in the Cabling**
- **Backwards Compatibility with 802.3at PDs.**

IEEE Project 802.3bu PoDL

- Parallel with 802.3bp
- Provide Power over 1 pair
- Power not defined yet

End to End Link

- **Began in IEC/SC65C/JWG10 ~ 5 years ago.**
- **Problem Statement**
- **Current Standards for Channel do not Define Cable in the Back end of the Two End Plugs of a Channel**
- **This Project Liaison with ISO/IEC/JTC1/SC25/WG3 (JMTG)**
- **Provide Modeling and Test Schedules for E2E Link**

E2E Link Continued

- **NWIP in ISO/IEC Was Circulated Earlier This Year**
- **Comments to NWIP Addressed in February Meeting in Japan.**
- **Modeling of Link is to be Completed**

Thank You

Questions?