



PoE, PoE++, PoDL – Enhancements to IEEE 802.3

**Bob Lounsbury
Rockwell Automation**

**Brad Woodman
Molex Inc.**

February 22, 2017

The IOT is exploding with far reaching applications such as Automotive, Home Automation, Building Automation, and Machine to Machine. Ethernet has become the universal communications network helping to drive this technology.

This paper will look the current status of the cabling standards such as IEC/SC65C/JWG10, ISO/IECJTC1/SC25/WG3 and ANSI TIA/TR42. In addition, this paper will focus on the status of IEEE 802.3 adaptations of standard Ethernet and the opportunities that it presents to ODVA. IEEE 802.3 committees releasing published a higher level PoE (PoE++) and Power over Data link (PoDL). These new powered enhancements can provide an attractive solution for powering a range of small devices up to larger IO devices. PoE++ is attractive for Industrial as it potentially can deliver some 90+ watts to the Powered Device (PD). Even more exciting are the number of newly proposed high speed single pair Ethernet adaptations being defined. These new adaptations will simplify the wiring and reduce space needed for the cabling in industrial installations.

The national and international cabling standards are already actively engaged with IEEE 802.3 working groups helping to define the cabling requirements for these new emerging networks. This paper will discuss the new industrial channel definitions (E2E Links) being defined by ISO/IEC that promise to help our customers successfully install and test their cabling.

Standardization of cabling systems for communications networks has been ongoing since the early 90s. Since the initial standardization of industrial cabling systems through ODVA there have been many new high performance components and enhancements proposed. The standards organizations continue to work to provide standardization of these new components and systems. There are several national and international cabling standards that have a direct impact on networks throughout the world. These standards are either based on ODVA network standards and/or are the foundation for the ODVA networks

This Presentation will focus on the current state of these standards and bring the audience up to date on how they affect ODVA. The standards committees are tightly linked and work together to create a complete system. Most of the connections are through Experts and Liaisons working between the committees. Through membership to these standards committees, ODVA provides input to the national and international standards.

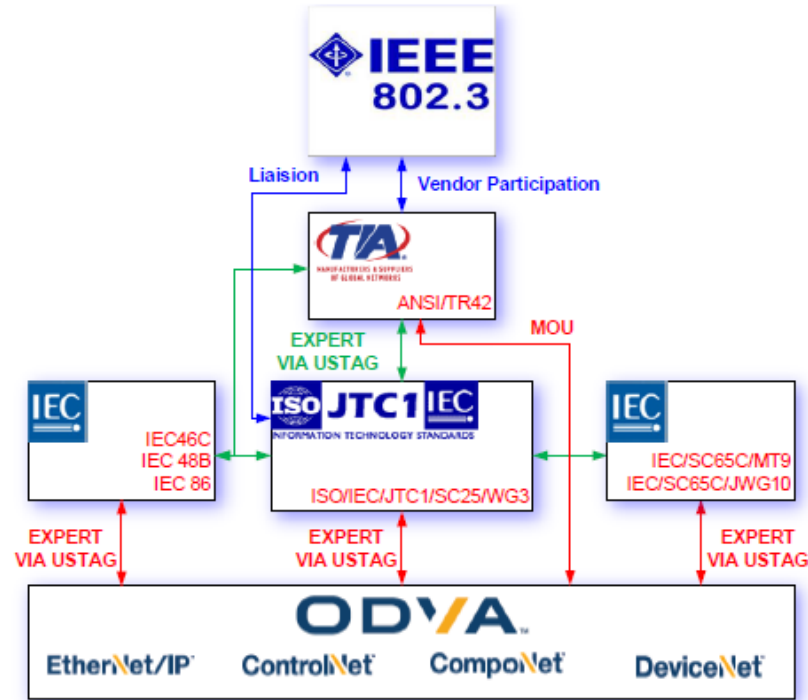

Interconnect of Cabling Standards

Cabling Standards International and National

Left Side Components, Center System Specifications, Right Side Installation

Interconnect of Standards Documents

Left Side Coverage, Center Design, Right Side Installation

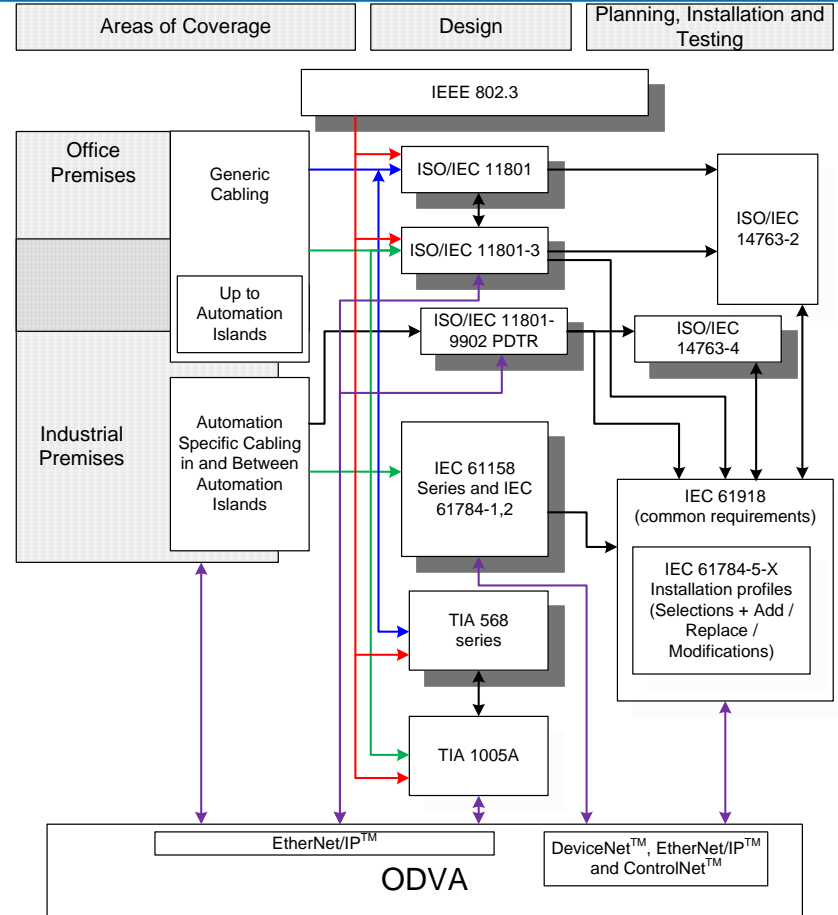

- IEEE 802.3 Projects
 - 802.3bp 1000BASE-T1, (RPTGE) – June, 2016
 - 1000Mb/s over Single Twisted Pair
 - Automotive 15 meters (link segment type A)
 - Industrial 40 meters (link segment type B)
 - New PHY
 - 802.3bw 100BASE-T1, – October, 2015
 - 100Mb/s over Single Twisted Pair
 - Automotive
 - Industrial
 - Length up to 15 meters
 - New PHY
 - 802.3cg 10BASE-T1, (10SPE) – late 2018
 - 10Mb/s over Single Twisted Pair
 - Length up to 1000 meters
 - New PHY

- IEEE 802.3 Projects continued
 - 802.3bu (PoDL) – October, 2016
 - Power Detection, Insertion and Extraction
 - Support all three single pair network

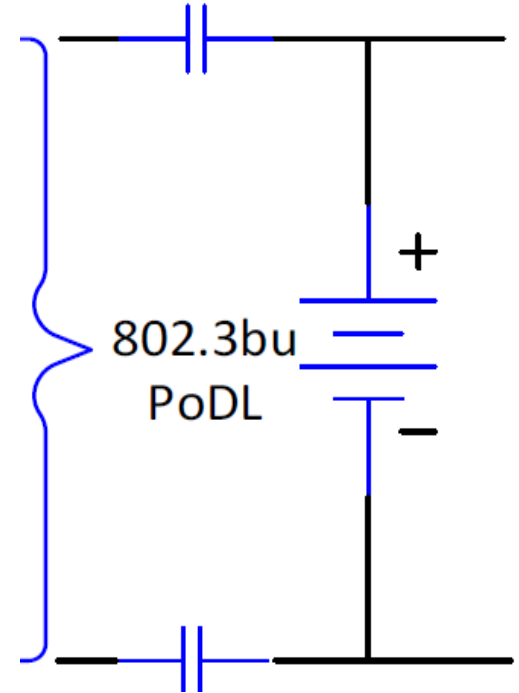
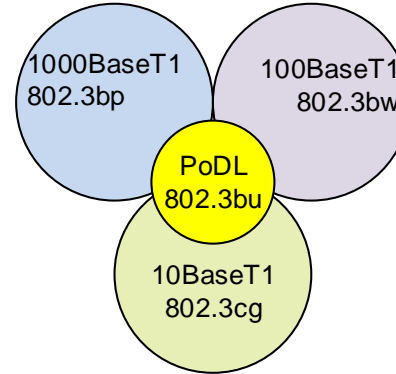

- IEEE 802.3 Projects continued
 - 802.3bz 2.5G/5GBASE-T – September, 2016
 - Based on 10GBASE-T at reduced signaling rate
 - 2.5Gb/s for Cat5e up to 100 meters
 - 5Gb/s for Cat 6 up to 100 meters

- Generic Cabling ISO/IEC 11801
 - Single Document now Redrafted into 6 Parts.
 - Release estimated summer 2017
 - MICE will be moved from TR29106 to the Main Part of ISO/IEC 11801
 - E2E Link Future Addition to ISO/IEC 11801
 - Part 1 – General Requirements
 - Part 2 – Office premises
 - Part 3 – Industrial premises (Contents of ISO/IEC 24702)
 - Part 4 – Homes
 - Part 5 – Data Centers
 - Part 6 – Distributed building services

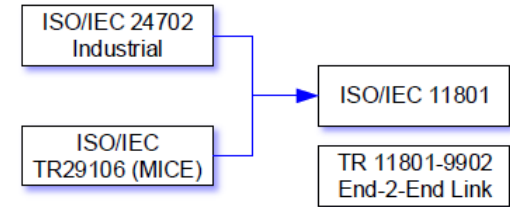

E2E Link

- Request from SC65C/JWG10
- Applicable to Data Centers
- Includes the Connections at the Two Ends of the channel in the performance limits
- Supports 1-4 Segment, 1-6 Connections
 - One Segment, 2 Connection
 - Two Segment, 3 Connection
 - Three Segment 4 Connection
 - Three Segment, Two 1 Connection Bulkheads, Total of 4 Connections
 - Three Segment, 6 Connections
 - Four Segment, 5 Connection
 - Five Segment, 6 Connection

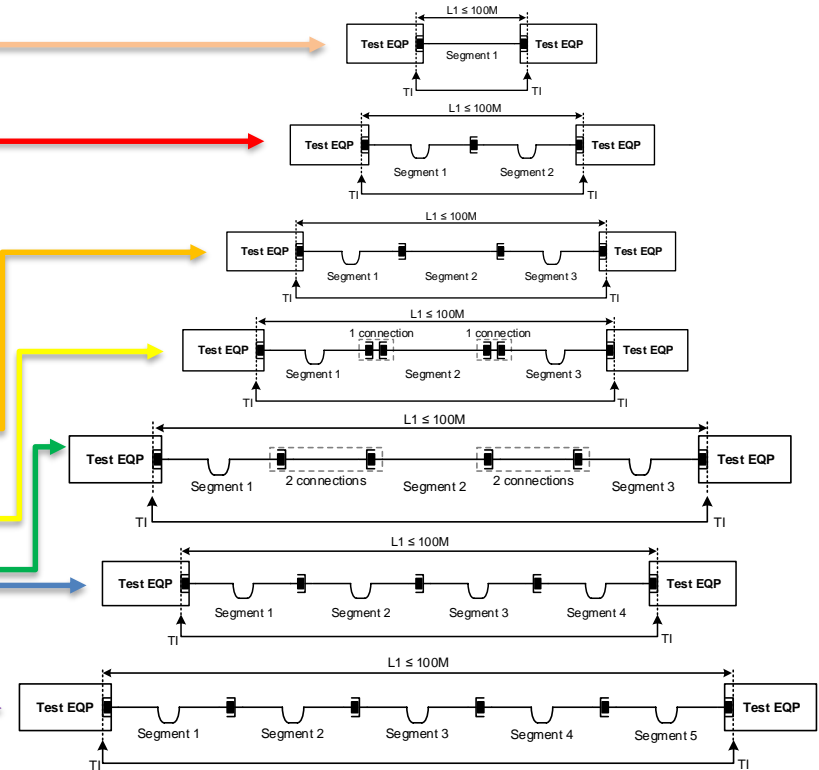

- E2E Link (continued)

- E2E link limits

- Insertion Loss Return Loss
- Next PSNext
- ACRF PSACRF
- TCL ELTCTL
- DC Loop Propagation Delay
- Delay Skew DC Unbalanced (Within a pair)

- The Current Test Schedule does not Require TCL and ELTCTL Testing in the Field.

- Classes EA and F are not Defined.

- Classes D and E CP Cords are Defined in an Informative Annex

- IEC 61918 stability date 2018
 - 1gigabit Industrial Cabling Requirements
 - E2E Link Will be Added
 - Reference to the Complement Field Testing Document IEC 14763-4
 - Two new Profiles Added -20 (ADS-net) and -21 (FL-net)
 - Now 19 Profiles in the IEC 61784-5-n Series, Hart and WORLDFIP are Listed but will not Submit a Profile.
 - PoE to be Added in This Cycle
 - IEEE 802.3 Single Pair Networks are Being Monitored

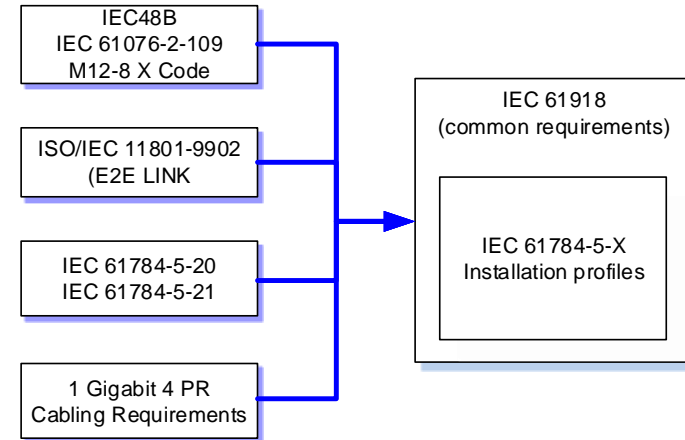

- IEC 48B
 - IEC 61076-114 – late 2017
 - M8 D-coding connector for single and two pair cable

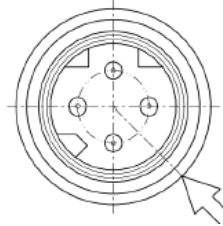

- Several other single pair connectors proposals currently under development

- TIA-1005-A
 - Two Addendums Currently Underdevelopment
 - 1 Gigabit Cabling Requirements
 - E2 and E3 levels
 - Testing on UTP and ScTP cables
 - 1000Base T1 (aka RPTGE, 802.3bp)
 - 1000Mb/s over Single Twisted Pair
 - Industrial (Link segment type B) up to 40M
 - • New PHY
 - TR 11801-9902 End-2-End Link

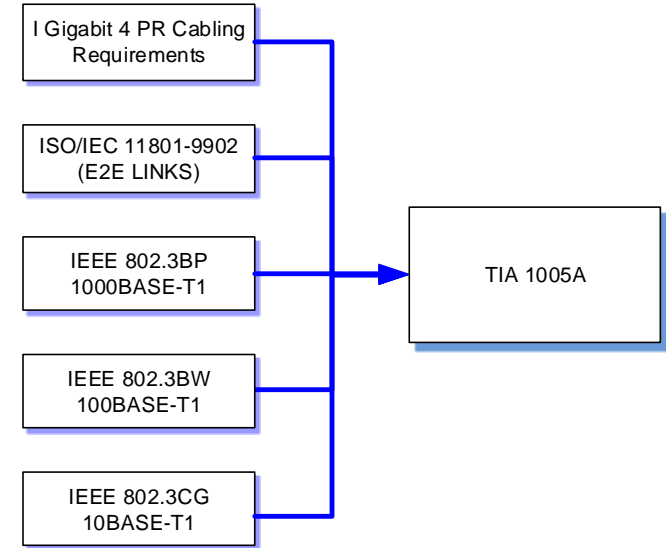

- 1 Gigabit cabling requirements
 - Conducted Immunity (Coupling clamp)
 - Electrical Fast Transient Burst (EFT/B)
 - Coupling Attenuation
- 1000Base-T1 (aka RPTGE, 802.3bp)
 - 1000Mb/s over Single Twisted Pair
 - Industrial (Link segment type B) up to 40M
 - • New PHY
- Chapter 8 reorganization
- TR 11801-9902 End-2-End Link
- Planning and Install Manual

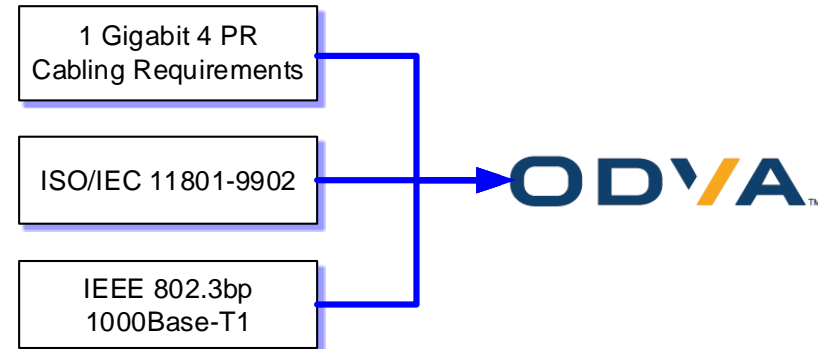



THANK YOU