



# Technology Management for Conformance Policy

Effective Date: May 7, 2014, Revised December 1, 2018

## 1 Introduction

This document supplements the ODVA Policy Regarding Compliant Products (PUB00008). Throughout this document the ODVA Policy Regarding Compliant Products will be referred to as PUB00008. This will reference the most current version of the policy. If there are any discrepancies between this document and PUB00008, PUB00008 will prevail.

Capitalized terms used herein that are not otherwise defined in this document shall have the meanings assigned in PUB00008.

Section 2 below complements PUB00008 by adding a set of technical definitions used in subsequent sections for the purpose of this document.

Section 3 below provides a description of the types of products for which conformance testing is provided. This section may be subject to changes as the list of technologies managed by ODVA evolves.

Section 4 below provides examples of the various possible implementations of the Compliant Products described in section 3.

Section 5 below defines the requirements for classifying Compliant Products as product families for conformance testing purposes.

Section 7 below lists the Requirements for Certification(s) by Third-Party Competent Bodies for Compliant Products.

Section 8 below defines the minimum content provided to vendors in the ODVA Conformance Test reports and Declaration of Conformity.

## 2 Definitions

This section complements the Definitions in PUB00008 by adding a set of technical definitions used in subsequent sections for the purpose of this document.

CIP Connector – A connector that is identified in the CIP Networks Library of Specifications.

CIP Device - A “node” (as defined in PUB00008) that contains 3 primary components: A single CIP Entity, at least one CIP Port and at least one CIP Connector.

CIP Entity – A logical component that contains an implementation of a profile described in Chapter 6 of Volume 1 (Common Industrial Protocol) of the CIP Networks Library but cannot function on the network without a CIP Port and associated object(s) and physical components. A CIP Entity has an Identity Object with at least Instance 1. In Modular Devices, multiple components may contain a CIP Entity.

CIP Infrastructure Product – Product that is in compliance with the CIP Networks Library of Specifications or other official ODVA documents but does not contain a CIP Port or CIP Entity. Examples include:

- Physical media, taps
- Connectors
- Power supplies
- Non-CIP network switches, repeaters and bridges

CIP Modular Device – A collection of modules which together contain at least one CIP Port, at least one CIP Connector and at least one CIP Module. Generally, no single modular component by itself can constitute a CIP Device. CIP Modular Devices often utilize a rack/chassis for their mechanical assembly, internal communications and/or distribution of power. The internal communication of such devices may or may not be based on CIP.

CIP Module – A product that contains a CIP Entity and is part of a CIP Modular Device.

CIP Multi-port Device – A “node” (as defined in PUB00008) that contains the following primary components: A single CIP Entity, at least two CIP Ports and at least two CIP connectors. All CIP Ports are associated with a CIP Entity in the device.

CIP Multi-port Module – A product that contains the following primary components: A single CIP Entity, at least two CIP Ports. All CIP Ports are associated with a CIP Entity in the device.

CIP Physical Media Attachment – A component inside a CIP Device that acts as an interface between a CIP Port and one or more CIP Connectors.

CIP Port – See Volume 1 of the CIP Networks Library, chapter 1 for port, definition section 1-7.

CIP Safety Device - A “node” (as defined in PUB00008) that contains 3 primary components: A single CIP Safety Entity, at least one CIP Safety Port and at least one CIP connector.

CIP Safety Entity – A logical component that contains a complete implementation of a profile described in Chapter 6 of Volume 5 (CIP Safety) of the CIP Networks Library but cannot function on the network without a CIP Safety Port and associated object(s) and physical components. A CIP Safety Entity has an Identity Object Instance 1 with at least the required attributes. In Modular Systems, multiple components may contain a CIP Safety Entity. A CIP Safety Entity includes a CIP Entity.

CIP Safety Module - A product that contains at least the following primary components: A single CIP Safety Entity and may contain a CIP Safety Port.

CIP Safety Multi-port Device – A “node” (as defined in PUB00008) that contains the following primary components: A single CIP Safety Entity, at least two CIP Safety Ports and at least two CIP connectors. All CIP Safety Ports are associated with a CIP Safety Entity in the device.

CIP Safety Multi-port Module – A product that contains a single CIP Safety Entity and at least two CIP Safety Ports. All CIP Safety Ports are associated with a CIP Safety Entity in the device.

CIP Safety Port – A CIP Port that supports the transport of the CIP Safety protocol.

## **3 CIP Compliant Product**

### **3.1 Overview**

ODVA issues Declarations of Conformity (DOC) for the following types of products:

- CIP Device (non-modular)
- CIP Module
- CIP Embedded Technology
- CIP Infrastructure

The following sections define the characteristics that ODVA will consider when granting DOCs to various products. No ODVA-managed technology is exempt from Conformance Testing. Please consult the ODVA Conformance Authority for any product that does not seem to be described by the following sections.

In addition to the .eds file, a correct Electronic Test Input File (currently an .stc file) for the product, created with ODVA's Protocol Conformance Test Software, must be provided at the time of the conformance test.

### **3.2 CIP Devices (*modular and non-modular*)**

CIP Devices and CIP Multi-port Devices contain both a single CIP Entity and one or more CIP Ports. A single Device Profile defines a CIP Entity. CIP Devices have a single CIP Port and CIP Multi-port Devices have two or more CIP Ports.

CIP Modules and CIP Multi-port Modules are part of a CIP Modular Device. CIP Modules may or may not have a CIP Port, but are part of a CIP Modular Device where one or more of the other modules in the device have one or more CIP Ports. CIP Modules with a CIP Port(s) are required to receive DOCs.

### 3.2.1 CIP Devices without CIP Safety

Figure 1 is an Entity Relationship Diagram (ERD) showing relations between components and indicating single-port products that are required or eligible to receive DOCs.

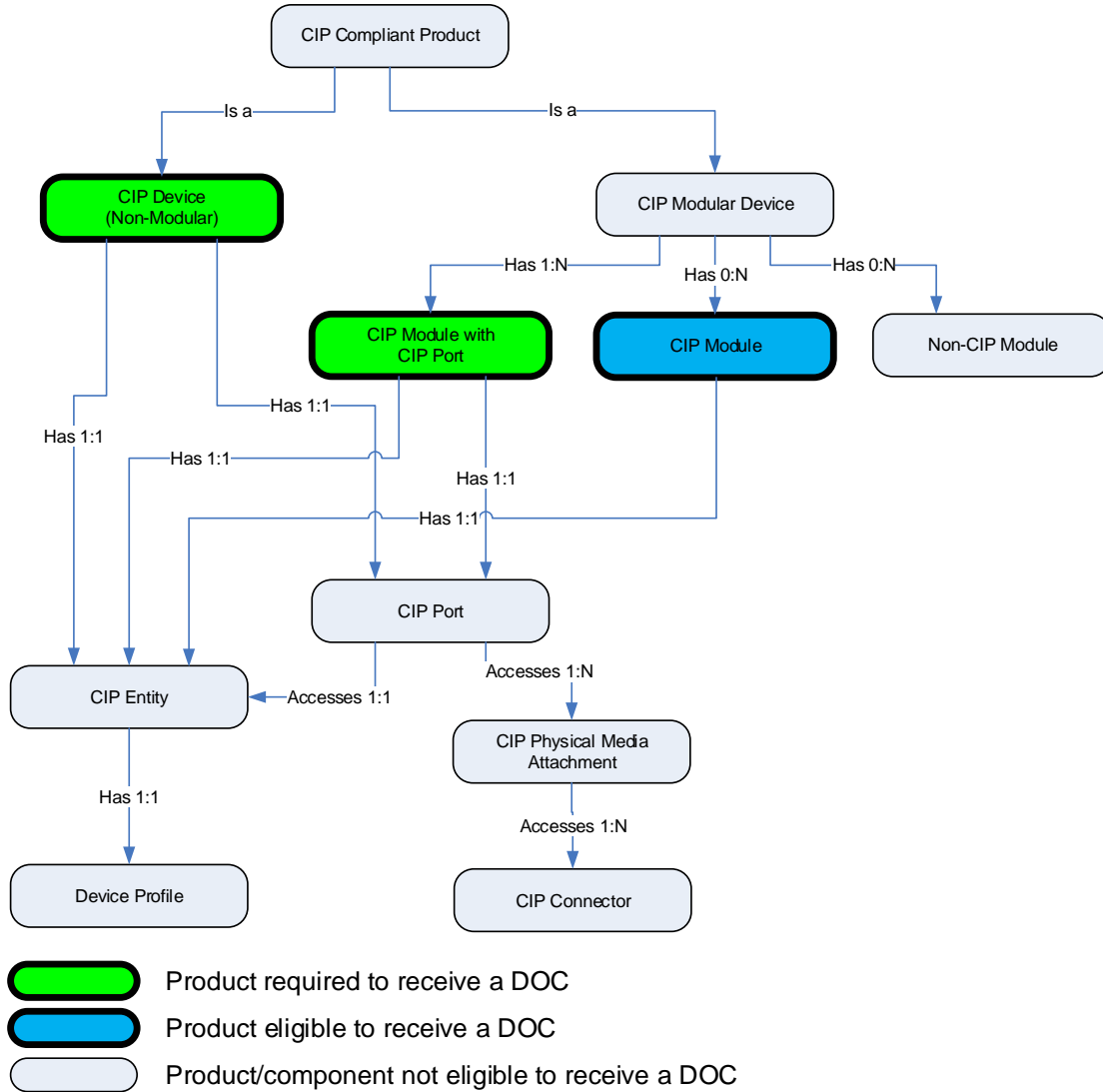

**Figure 1: CIP Compliant Single-port Product ERD**

Figure 2 is an ERD showing relations between components and indicating Multi-port products that are required or eligible to receive DOCs.

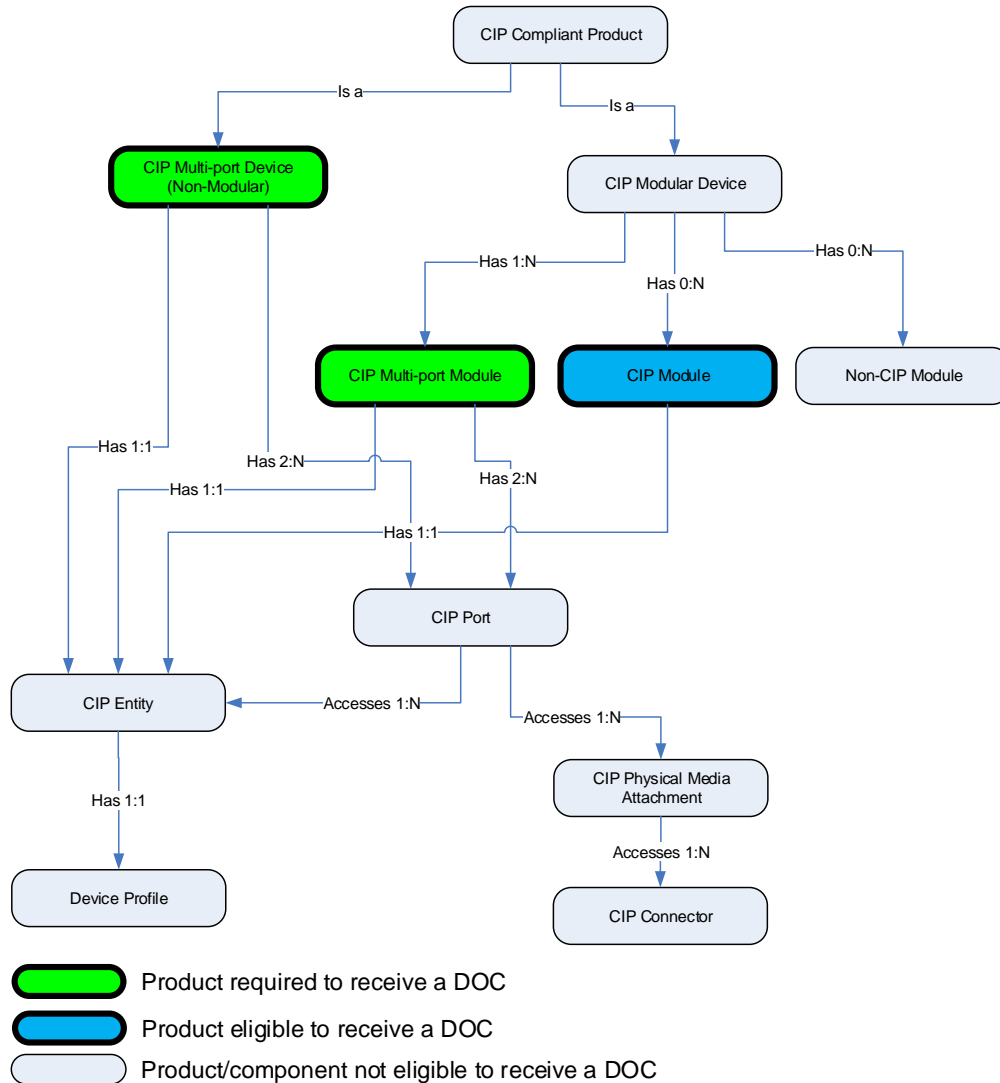

**Figure 2: CIP Compliant Multi-port Product ERD**

### 3.2.2 Devices with CIP Safety

CIP Safety Devices and CIP Safety Multi-port Devices contain both a single CIP Safety Entity and one or more CIP Safety Ports. Each safety entity is defined by a single Safety Device Profile. CIP Safety Devices have a single CIP Safety Port and CIP Safety Multi-port Devices have 2 or more CIP Safety Ports.

CIP Safety Modules and CIP Safety Multi-port Modules are part of a CIP Modular Device. The CIP Modular Device has one or more CIP Entities. CIP Safety Modules may or may not have a CIP Port, but are part of a CIP Modular Devices where one or more of the other modules in the system has one or more CIP Ports. CIP Safety Modules with or without a CIP Safety Port(s) are required to receive DOCs. CIP Modules with a CIP Port(s) are required to receive DOCs.

Figure 3 is an ERD showing relations between CIP components and indicating products that are required or eligible to receive DOCs.

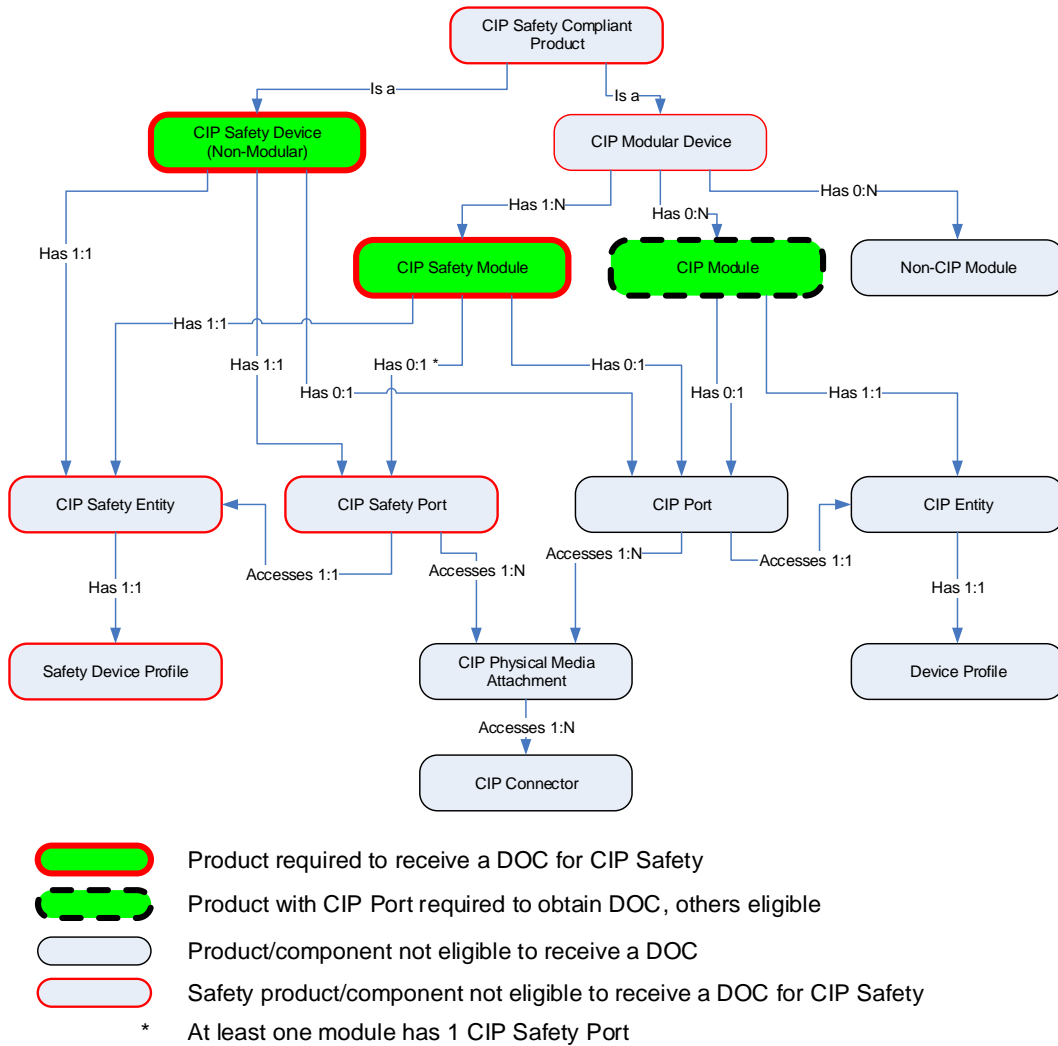

**Figure 3: CIP Safety Compliant Single-port Product ERD**

Figure 4 is an ERD showing relations between CIP components and indicating multi-port products that are required or eligible to receive DOCS.

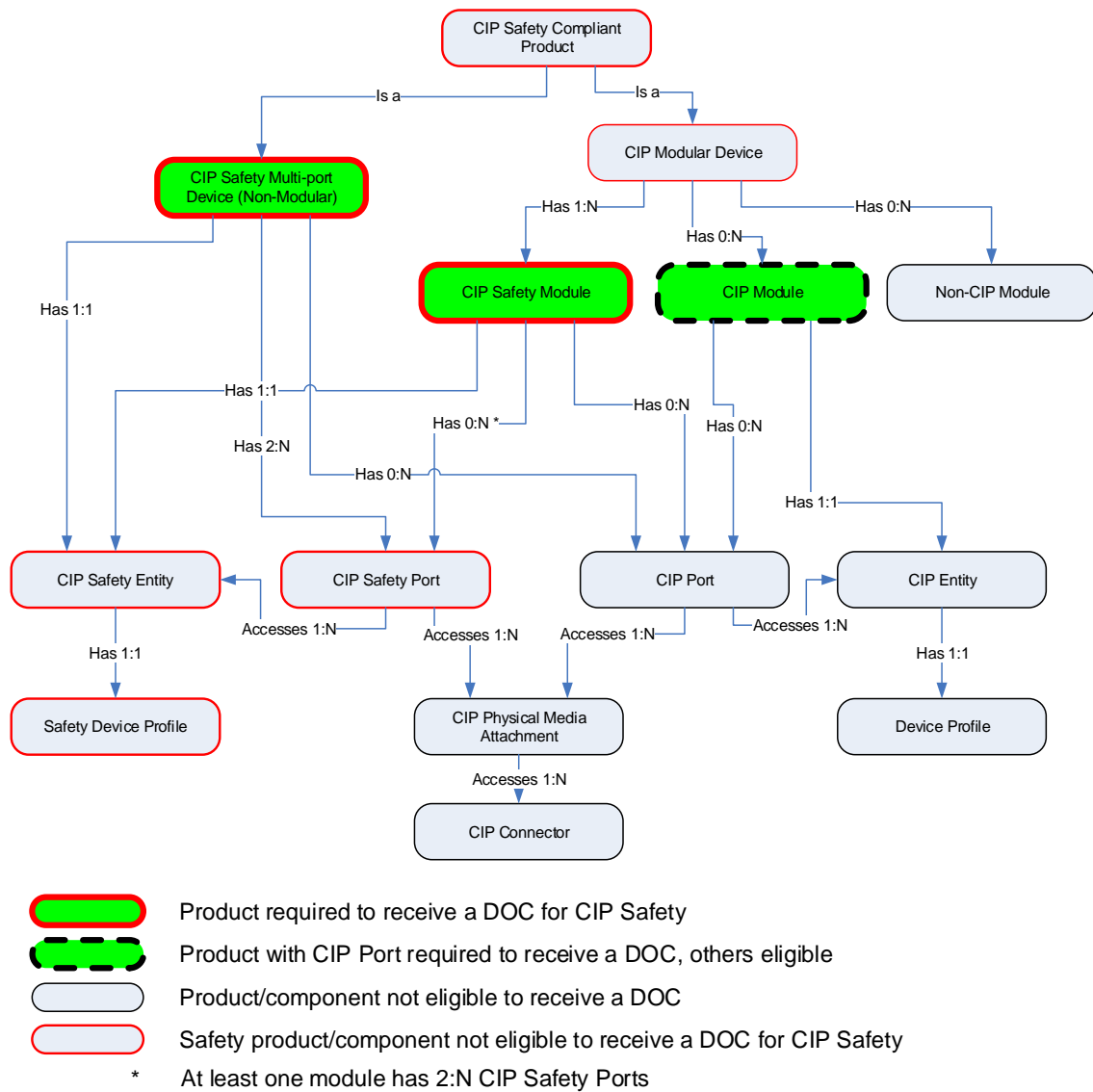

Figure 4: CIP Safety Compliant Multi-port Product ERD

### 3.3 CIP Embedded Technology Products

CIP Embedded Technology Products may be electronic assemblies, FPGAs, ASICs, firmware stacks and/or software. In order to be classified as an embedded technology, the implementation to be used by Derivative Products must contain one or more CIP Entities or CIP Objects. CIP Embedded Technology Products must have at least some elements of a CIP Port but do not need to contain a CIP Physical Media Attachment including a CIP Connector. For testing purposes, the Licensed Vendor of CIP Embedded Technology must submit a typical complete application for conformance testing, including CIP Physical Media Attachment and CIP Connector, plus a

sample application (reference platform) that demonstrates that the CIP Embedded Technology can effectively be used to successfully build Derivative Products.

Products implementing CIP Embedded Technologies (i.e. Derivative Products) are required to be tested at an ODVA-authorized Test Service Provider and obtain a DOC. This will retest the CIP Embedded Technology for each product tested to verify that no errors have been introduced in the adaptation and/or extension of the CIP Embedded Technology to the Derivative Product.

### **3.4 CIP Infrastructure Products**

This category includes DeviceNet power supplies; DeviceNet, ControlNet and CompoNet cables, taps and connectors; EtherNet/IP cables and connectors, repeaters and network switches. Ethernet switches with a CIP Entity inside are treated as CIP Devices.

ODVA currently issues DOCs for the following infrastructure devices:

- DeviceNet power supplies
- CompoNet repeaters

### **3.5 Other Products**

If a product is not described by the previous sections and is not covered by the examples in section 4, the Licensed Vendor of the product shall contact the ODVA Conformance Authority to discuss how the product will achieve compliance with the Licensed Vendor's Terms of Usage Agreement.

## **4 Examples of CIP Compliant Products**

The following are examples of possible implementations that would be eligible for a DOC.

All of the examples share the following key:

- D – CIP Device (non-modular)
- M – Module (part of a CIP Modular Device)
- MD – CIP Modular Device
- C – CIP Connector
- P – CIP Port
- E – CIP Entity
- EC – Embedded Circuit (Embedded Technology)
- S – CIP Stack (Embedded Technology)

### **4.1 CIP Device with Single Network Connection**

In the example of the CIP Device shown in Figure 5, the CIP Entity, CIP Port and the CIP Connector are required to be conformance tested and the Discrete Block I/O is required to receive a DOC.



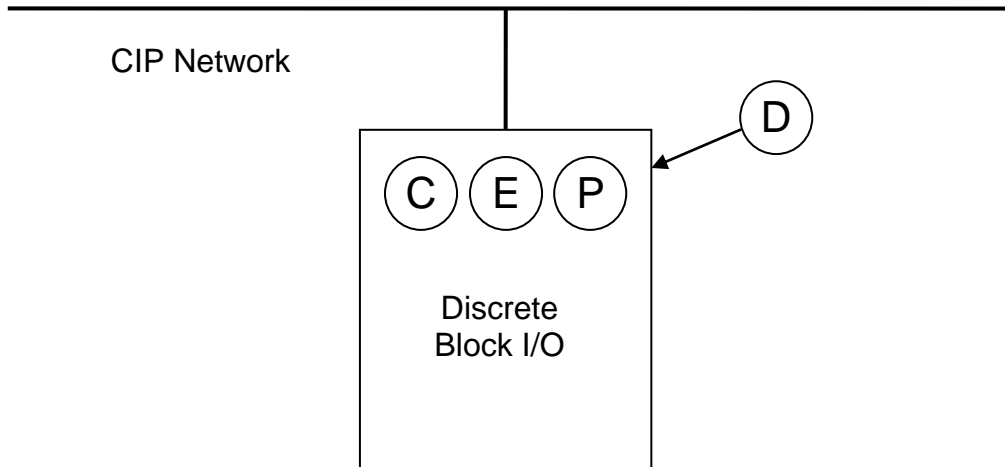

Figure 5: CIP I/O Block

#### 4.2 CIP Modular Device with Single Network Connection

In the example of the CIP Modular Device shown in Figure 6, the Controller Module is eligible to receive a DOC, since it implements a CIP Entity. The Communications Adapter is required to obtain a DOC since it connects directly to a CIP Network (i.e. contains a CIP Port). The Discrete I/O Module is not eligible to receive a DOC.

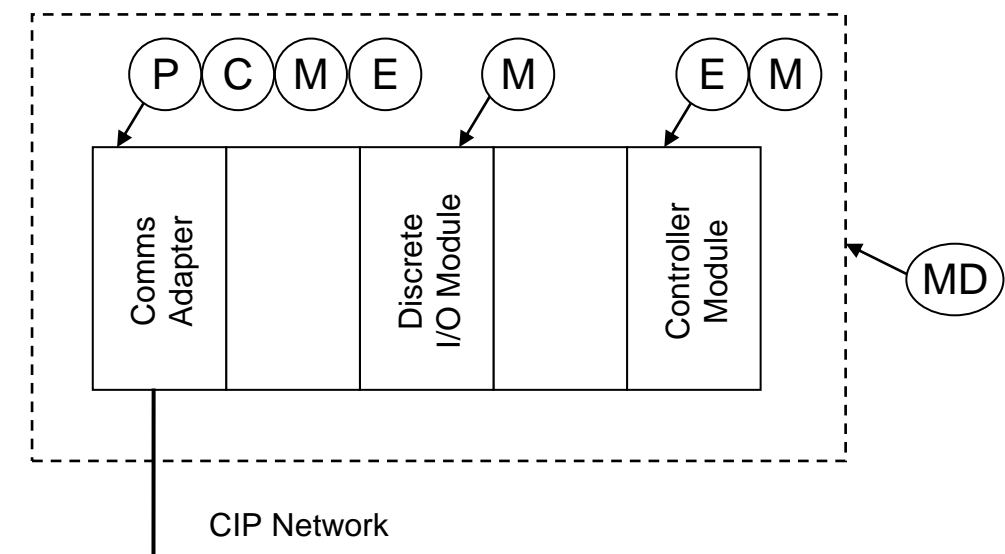

Figure 6: CIP Modular Device with Single Network Connection

#### 4.3 CIP Device with Multiple CIP Network Connections

In the example of the CIP Device shown in Figure 7, the CIP Router is required to receive a DOC listing compliance with both the EtherNet/IP and DeviceNet networks. The CIP Entity, CIP Ports and the CIP Connectors are required to be conformance tested.

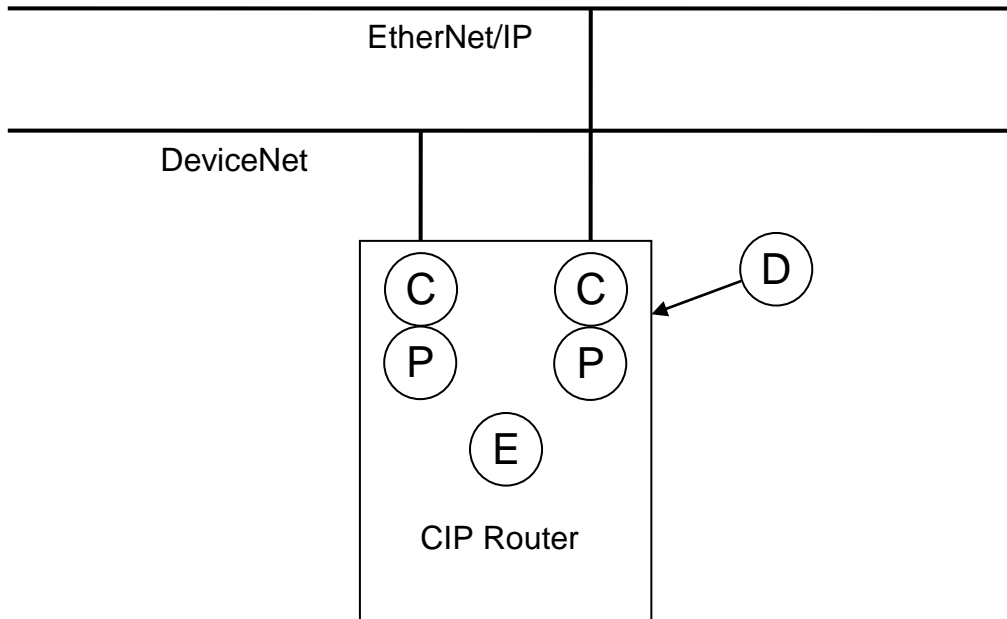

Figure 7: CIP Device with Multiple CIP Network Connections

#### 4.4 CIP Modular Device with Multiple CIP Network Connections

In the example of the CIP Modular Device shown in Figure 8, the Discrete I/O Module and the Controller Module are eligible to receive a DOC, since they implement a CIP Entity. Each Communications Adapter is required to obtain a DOC since it connects directly to a CIP Network (i.e. contains a CIP Port).

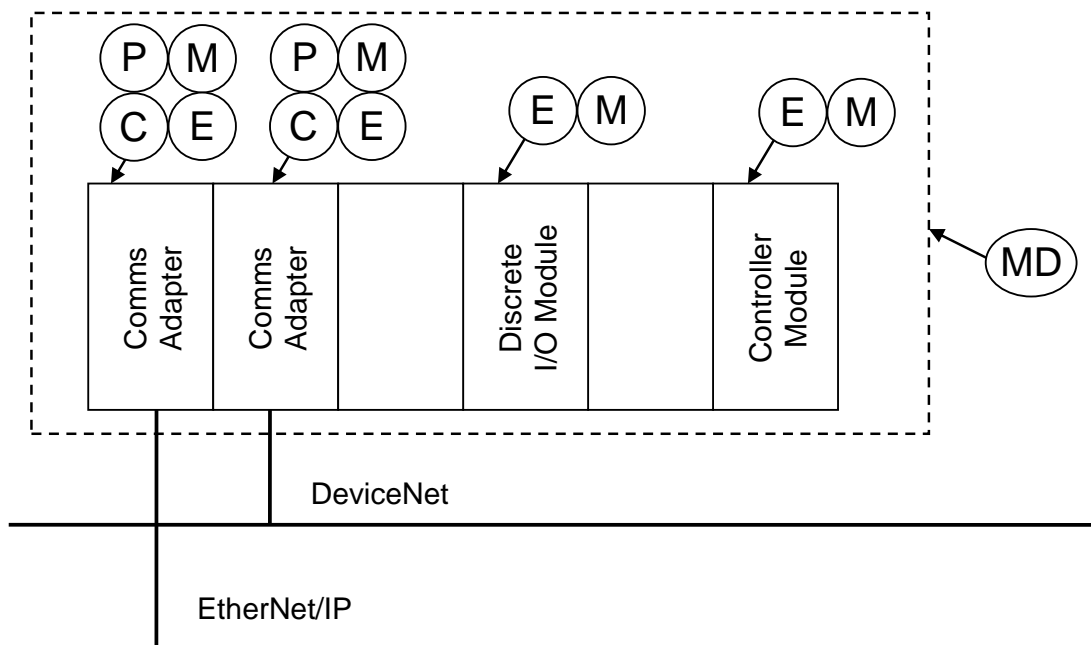
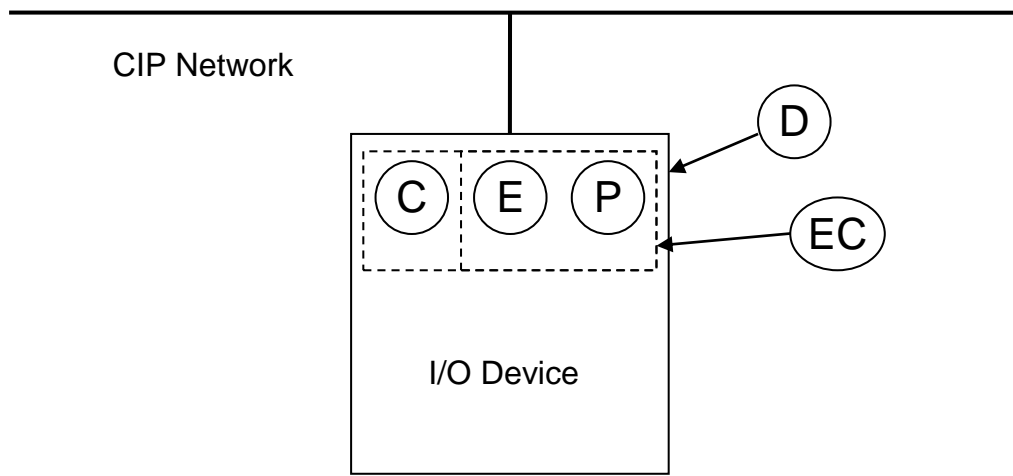

Figure 8: CIP Modular Device with Multiple CIP Network Connections

#### **4.5 CIP Device with Single Network Connection using Embedded Circuit**

In the example shown in Figure 9, the CIP Device was constructed using a CIP Compliant Embedded Technology from another vendor which already has received a DOC for the Embedded Circuit. The Discrete Block I/O is required to be tested separately to receive a DOC.

Note: The Embedded Technology Circuit may include the CIP Connector, the CIP Entity, and the CIP Port or any combination of the elements that make up a CIP device.



**Figure 9: CIP Device with Single Network Connection Using Embedded Technology Circuit**

#### **4.6 CIP Device with Single Network Connection using a CIP Stack**

In the example shown in Figure 10, the CIP Device was constructed using a CIP Compliant Embedded Technology (i.e. CIP Stack) from another vendor which already has received a DOC for the CIP Stack. The Discrete Block I/O is required to be tested separately to receive a DOC.

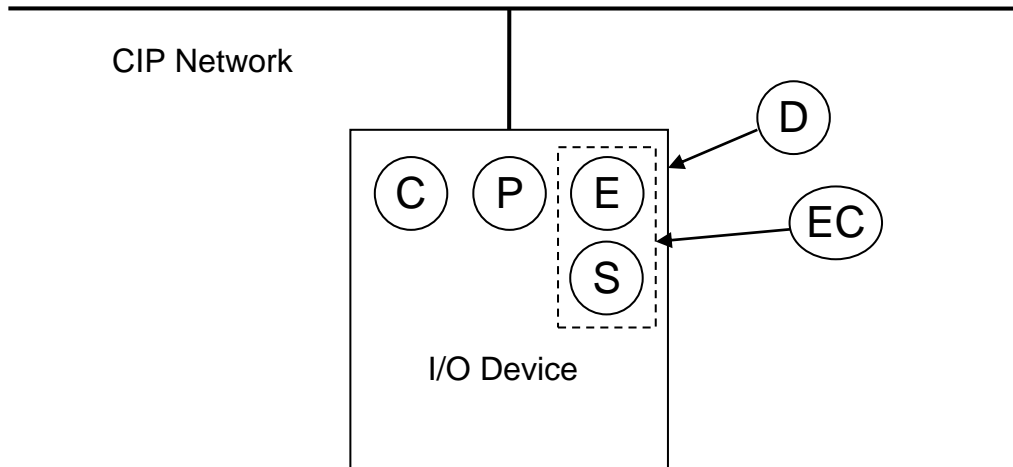

Figure 10: CIP Device with Single Network Connection using CIP Stack

## 5 Criteria for Classification as a Product Family

If a group of two or more products implements a common ODVA technology, the Licensed Vendor may request to have the group classified as a “Product Family” as specified in PUB00008, provided that the group meets the criteria below.

All Products must implement the identical Device Type (e.g. AC Drive), ODVA technology (e.g. DeviceNet, EtherNet/IP), and identical firmware/software (i.e. identical binaries) and exhibit one or more of the following differences:

- The values of the product-specific identifiers in the Identity Object, at least attributes 3 (Product Code) and/or 7 (Product Name), vary between products as required to delineate different members of the family;
- Members may have different variants of one or more network-related physical layer components (e.g. network connector) – All physical layer variants must be submitted to the Conformance Test.
- Members may exhibit minor product variations in features not related to the ODVA technology (e.g. number and location of I/O points).
- Addition of new members to the product family is subject to re-test. Re-test may consist of a new full conformance test or a Partial Conformance Test by Licensed Vendor as specified in Appendix A of PUB00008 – Policy Regarding Compliant Products. The ODVA Conformance Authority makes a decision regarding the re-test type based on the vendor description of the changes made to the firmware/hardware family since the last family conformance test. No Partial Conformance Test by Licensed Vendor is allowed for CIP Safety products.

## 6 Advisory Declarations

Certain types of Compliant Products can receive an Advisory Declaration (AD) after going through additional testing (Adjunct Tests) beyond what is needed to receive a DOC. Passing the Adjunct Test will be documented in the DOC as an Advisory Declaration.

ADs can currently be issued for:

- EtherNet/IP Interoperability
  - ✓ The product has to pass the EtherNet/IP PlugFest which verifies the product compliance with ODVA PUB00070 Recommended Functionality for EtherNet/IP Devices.

- DeviceNet Semiconductor
  - ✓ The product has to pass the DeviceNet Semiconductor Adjunct Test to verify compliance with ODVA PUB00262 Interface Guidelines for Semiconductor Devices, which is distributed with [The DeviceNet Specification](#).

## 7 Requirements for Certification(s) by Third-Party Competent Bodies for CIP Products

### 7.1 Devices and Modules, CIP ONLY

All Network technologies: No Third Party Competent Bodies have been approved.

### 7.2 Devices and Modules, CIP SAFETY

All Safety Network technologies:

To receive a DOC, a CIP Safety product shall follow this sequence:

- Test of the product at an ODVA TSP and receive a passing verdict
- Provide test report to an ODVA-authorized Third-Party Competent Body, currently TÜV Rheinland
- Obtain Certificate of Compliance to IEC 61508 issued by TÜV Rheinland
- Provide TÜV Rheinland certificate to ODVA
- ODVA will issue CIP Safety DOC

Additional certification requirements, to allow Declaration of Conformity for CIP Safety products certified to less than SIL3, are contained in Edition 2.16 (or later) of The CIP Safety Specification.

If the Certificate of Compliance to IEC 61508 does not indicate SIL3, then Systematic Capability SC3 shall be declared either on the Certificate itself or in an associated report issued by the safety certifying agency.

If the Certificate of Compliance to IEC 61508 is for a separately certified implementation of CIP Safety (e.g. Embedded Technology) that is part of the tested product, then the integration of the CIP Safety implementation into the tested product shall be certified to provide either SIL3 or SC3.

All certificates and reports shall be clearly traceable to the tested CIP Safety product. Upon receipt and following the normal process for issuing DOCs, ODVA issues a DOC for CIP Safety product.

If Vendor wishes to use an alternate Functional Safety Certification Organization, additional charges may be incurred by the Vendor. Please contact ODVA as early as possible in your development process to discuss.

## 8 Test Reports and Declaration of Conformity

This section defines the contents generally found in all ODVA TSP test reports as well as the information provided in the DOCs issued by ODVA.

## **8.1 Test Report and DOC Information**

### **8.1.1 Test Report**

A sample Test Report is distributed with the Protocol Conformance Test Software Tool available for ODVA networks.

The Test Report includes the following information (not a comprehensive list):

- Test Information (CT revision, Test Date, Test Type, ODVA File Number)
- Vendor Information (Vendor Name)
- Device Information (Identity Object Attribute Values)
- TSP Information (Location)
- Test Failures and Advisories
- Product Family Members

### **8.1.2 DOC Information**

A sample DOC is distributed with the Protocol Conformance Test Software Tool available for ODVA networks.

The DOC includes the following information (not a comprehensive list):

- Test Information (Vendor Name, CT Revision, Test Date, ODVA File Number)
- Product Information (Identity Object Attribute Values, SOC File Name)
- Advisory Tests
- Product Family Members.