



**ODVA**  
**2009**  
CIP Networks Conference  
and 13th Annual Meeting

# Introduction to Device Level Ring

Anatoly Moldovansky, Sivaram Balasubramanian, and Brian Batke  
Rockwell Automation

---

**Technical Track**

[www.odva.org](http://www.odva.org)

# What is Device Level Ring?

- Also known as “DLR”
- Layer 2 protocol
- Allows multi-port EtherNet/IP devices to operate in ring topologies
- Published in EtherNet/IP specification, November, 2008
  - ODVA conformance test development in progress
  - First products available Spring, 2009

# Why Ring Topology?

- End users want it
- Well, first they want linear topology:

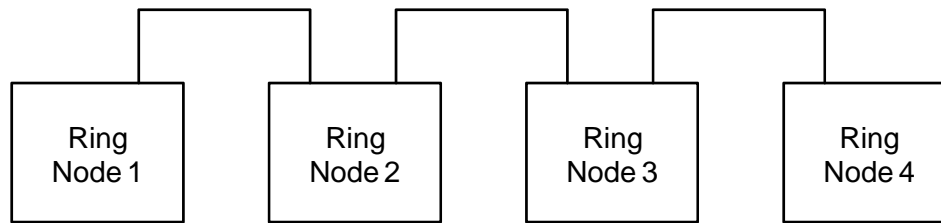

- **Why?**
  - ▶ Reduce cost of switches; simplify network cabling
  - ▶ Fits physical layout of certain applications
  - ▶ Problem: break in network means loss of communications
  - ▶ Solution: make the line into a ring

# Why is DLR needed?

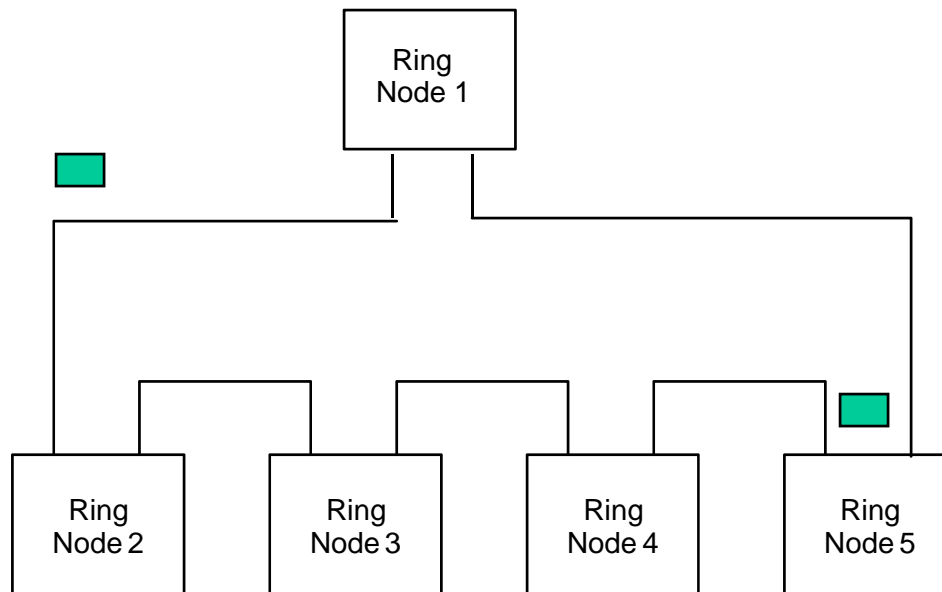

**In a ring with no ring protocol, packets would circulate forever!**

# DLR Functions

## The DLR protocol defines a set of frames and associated behaviors:

- ▶ Ring Supervisor to keep frames from circulating infinitely around the ring
- ▶ Detection of breaks in the ring and reconfiguration to a linear topology
- ▶ Detection of ring restoration and reconfiguration to ring mode

# Normal Operation

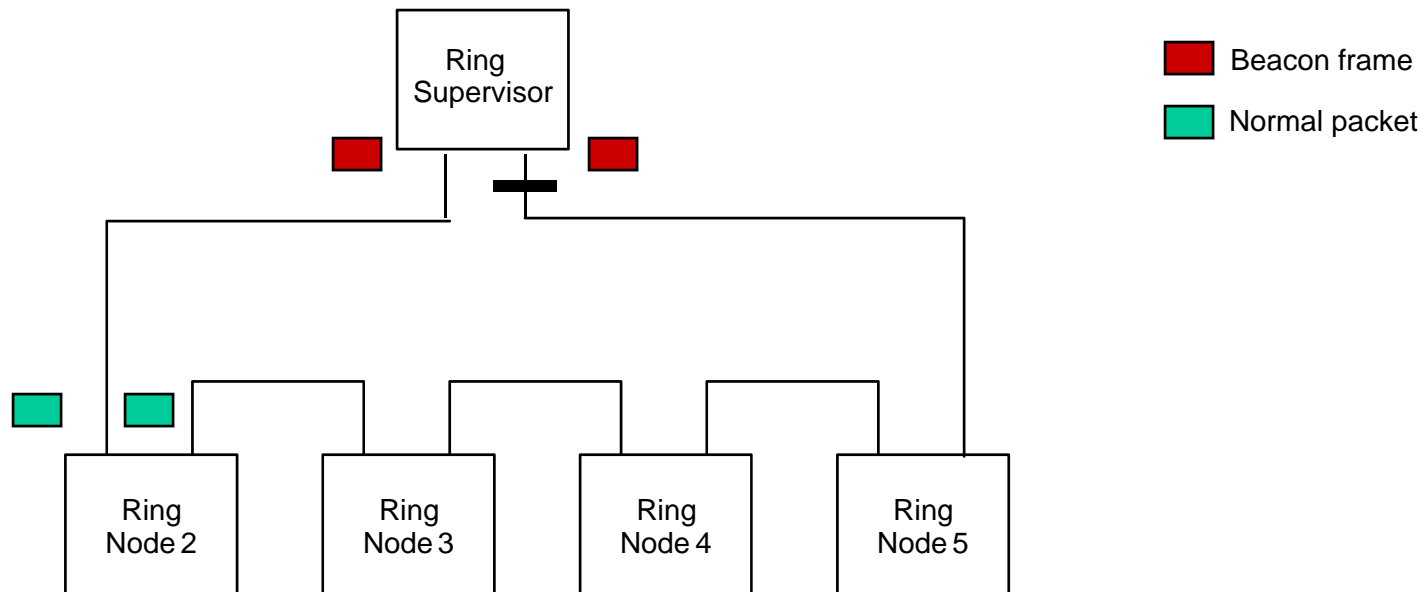

- Supervisor blocks traffic on one port
- Sends Beacon frames on both ports to detect break in the ring
- Sends Announce frames on unblocked port

# Physical Link Failure

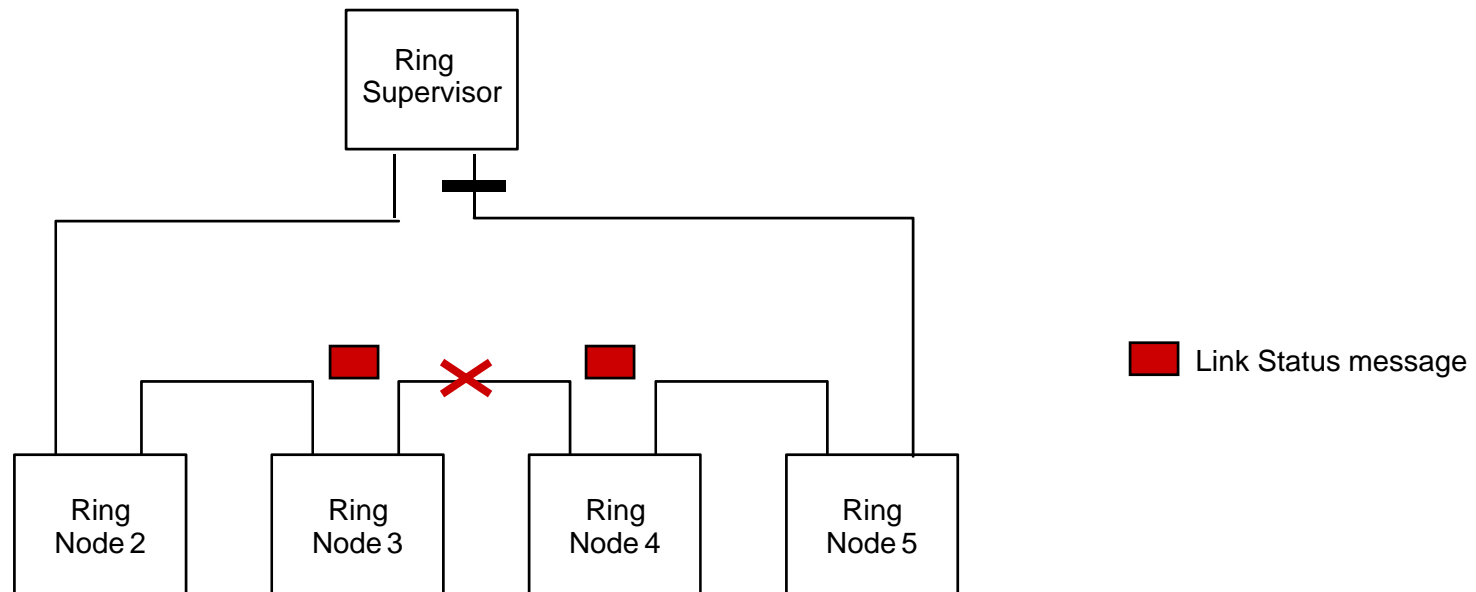

- ▶ Physical layer failure detected by protocol-aware node
- ▶ Link Status message sent by ring node and received by ring supervisor

# Reconfiguration After Failure

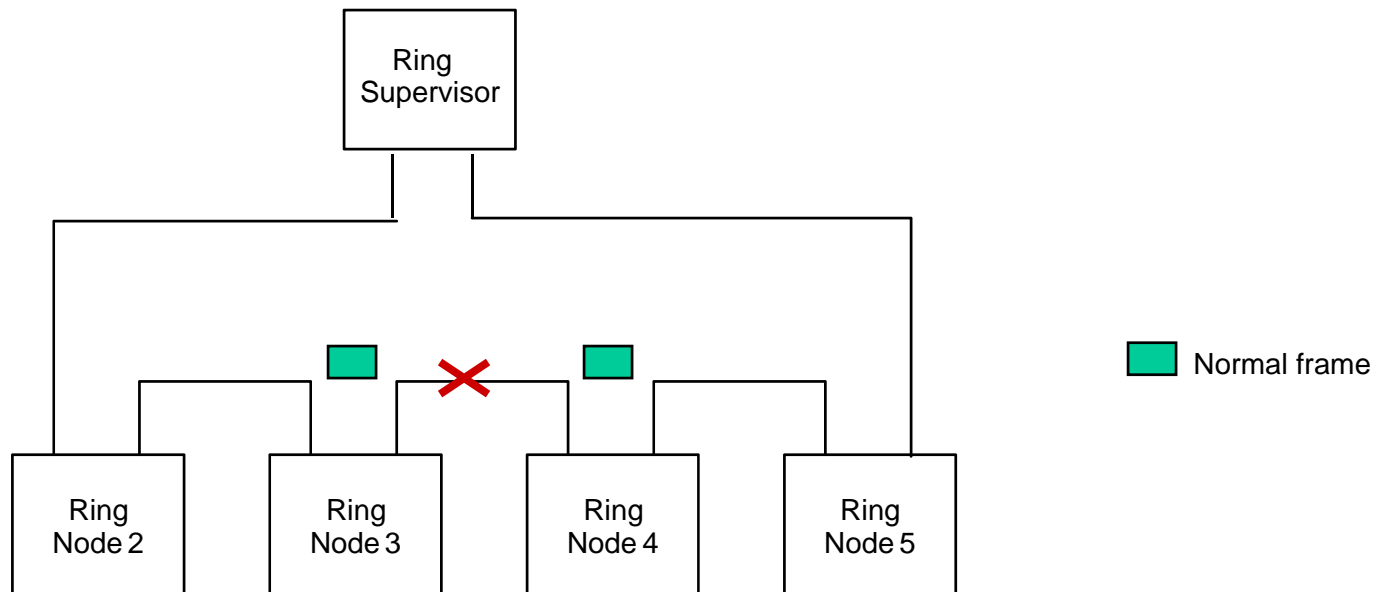

- ▶ Supervisor unblocks blocked port
- ▶ Network configuration is now a linear topology
- ▶ Fault location is readily available
- ▶ If ring is restored, transitions to normal ring mode

# Failure Not Detected at Physical Layer

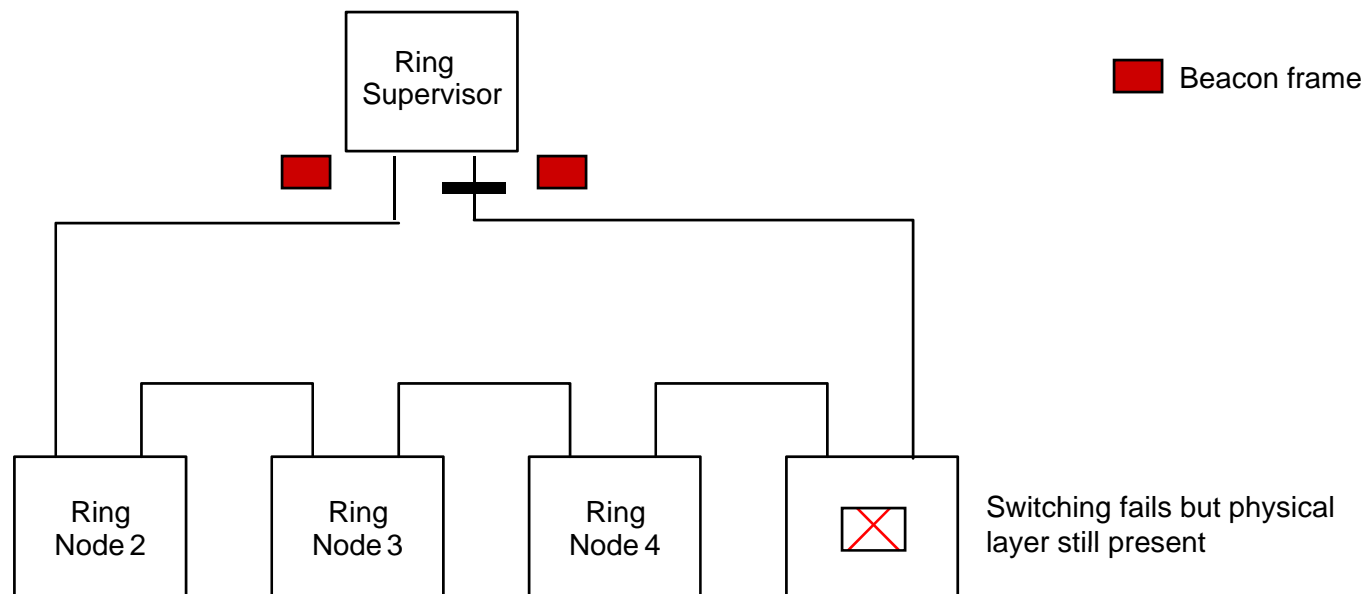

- ▶ Supervisor detects loss of beacon; unblocks port
- ▶ Fault location is identified via the neighbor check mechanism
- ▶ If ring is restored, supervisor hears beacon on both ports, and transitions to normal ring mode

# Abnormal Failures

## Partial Network Fault

- ▶ Traffic flows in only one direction

## Rapid Faults

- ▶ Defined as 5 faults in 30 seconds

## In both cases:

- ▶ Supervisor segments network requiring user intervention
- ▶ Fault location may be identified through Neighbor Check mechanism

# Classes of DLR Implementation

## Ring Supervisor

- ▶ Implements ring supervisor functions
- ▶ Must be able to send and process Beacon frames at default rate of 400us
- ▶ Future spec enhancement to allow slower default

## Ring Node, Beacon-Based

- ▶ Implement protocol, but not ring supervisor
- ▶ Must be able to process Beacon frames

## Ring Node, Announce-Based

- ▶ Implement protocol, but not ring supervisor
- ▶ Not required to process Beacon frames in CPU
- ▶ Must process Announce frames to detect network reconfig
- ▶ Generally slower to detect and respond to network reconfig

# DLR Ring Supervisor

- ▶ One or more nodes can be configured as Ring Supervisor but there is one Active Ring supervisor
  - Active supervisor is selected based on user configured precedence sequence
- ▶ The Active Ring Supervisor:
  - Sends Beacon and Announce frames
  - Prevents frames from circulating
  - Reconfigures network on ring break & restoration
- ▶ At least one supervisor must be configured before ring is closed

# DLR Messages

## Layer 2 messages (Ethertype 0x80E1), sent with 802.1Q tag (priority 7):

- ▶ Beacon
- ▶ Announce
- ▶ Neighbor\_Check\_Request
- ▶ Neighbor\_Check\_Response
- ▶ Link Status/Neighbor\_Status
- ▶ Locate\_Fault
- ▶ Sign\_On

# Beacon and Announce Frames

## Beacon Frame

- ▶ Supervisor sends through both ports once per Beacon Interval (default 400us)
- ▶ Also sent on change of ring state

## Announce Frame

- ▶ Supervisor sends once per second, and on ring state change

## Purposes

- ▶ Inform ring nodes to transition from linear to ring and vice-versa (flush MAC tables)
- ▶ Loss of Beacon frames enables detection of certain ring faults
- ▶ Beacon frames carry a precedence value, allowing selection of an active supervisor

# Implementation Requirements

- ▶ Implement DLR protocol messages and associated behaviors (Chapter 9 in Volume 2)
- ▶ Implement DLR Object (Chapter 5)
- ▶ Embedded switch implementation must give highest priority to DLR frames:
  - Based on EtherType (preferred) or VLAN tag priority
  - ODVA QoS with 4 queues (preferred) or at least 2 queues
- ▶ Flush unicast/multicast address filter tables on all state changes
  - Or disable unicast/multicast address filtering

# Non-DLR Nodes

- ▶ DLR-unaware nodes **MAY** be placed in the ring (e.g., existing 2 port devices)
  - Can make ring recovery slower
  - **IMPORTANT:** Requires certain behavior from the device (MAC learning must be disabled)
  - Recommended solution is to connect unaware devices via a 3-port protocol-aware switch.

# Performance

Number of Ring Nodes	Beacon Interval (μs)	Round Trip Time <sup>1</sup> (μs)	Beacon Timeout (μs)	Physical Layer Faults Recovery Delay <sup>1</sup> (μs)	Non-physical Layer Faults Recovery Delay for Beacon Frame Based Nodes (μs)	Non-physical Layer Faults Recovery Delay for Announce Frame Based Nodes (μs)	Ring Restore Delay for Beacon frame Based Nodes (μs)	Ring Restore Delay for Announce frame Based Nodes (μs)
25	400	905	1380	980	1858	2335	1330	2260
<b>50</b> <b>(nominal network size)</b>	400	1810	1960	1885	<b>2890</b>	3820	2235	4070
100	400	3620	3120	3695	4955	6790	4045	7690
150	400	5430	4280	5505	7020	9760	5855	11310
200	400	7240	5440	7315	9085	12730	7665	14930
250	400	9050	6600	9125	11150	15700	9475	18550

1. Same for Beacon and Announce frames based nodes.

## Performance (cont.)

- ▶ Performance assumes DLR frames delayed by mostly EtherNet/IP traffic of 128-byte frames on 90% of nodes and maximum sized (1522-byte) frames on 10% of nodes
  - On wire overhead of 20-bytes per frame and internal switching delay of 5 $\mu$ s per node is considered in calculations
- ▶ The worst case fault recovery time for a 50-node Beacon-based DLR network is less than 3ms.

# Supported Topologies

The DLR protocol supports a simple, single-ring topology. A network installation may however use more than one DLR-based ring.

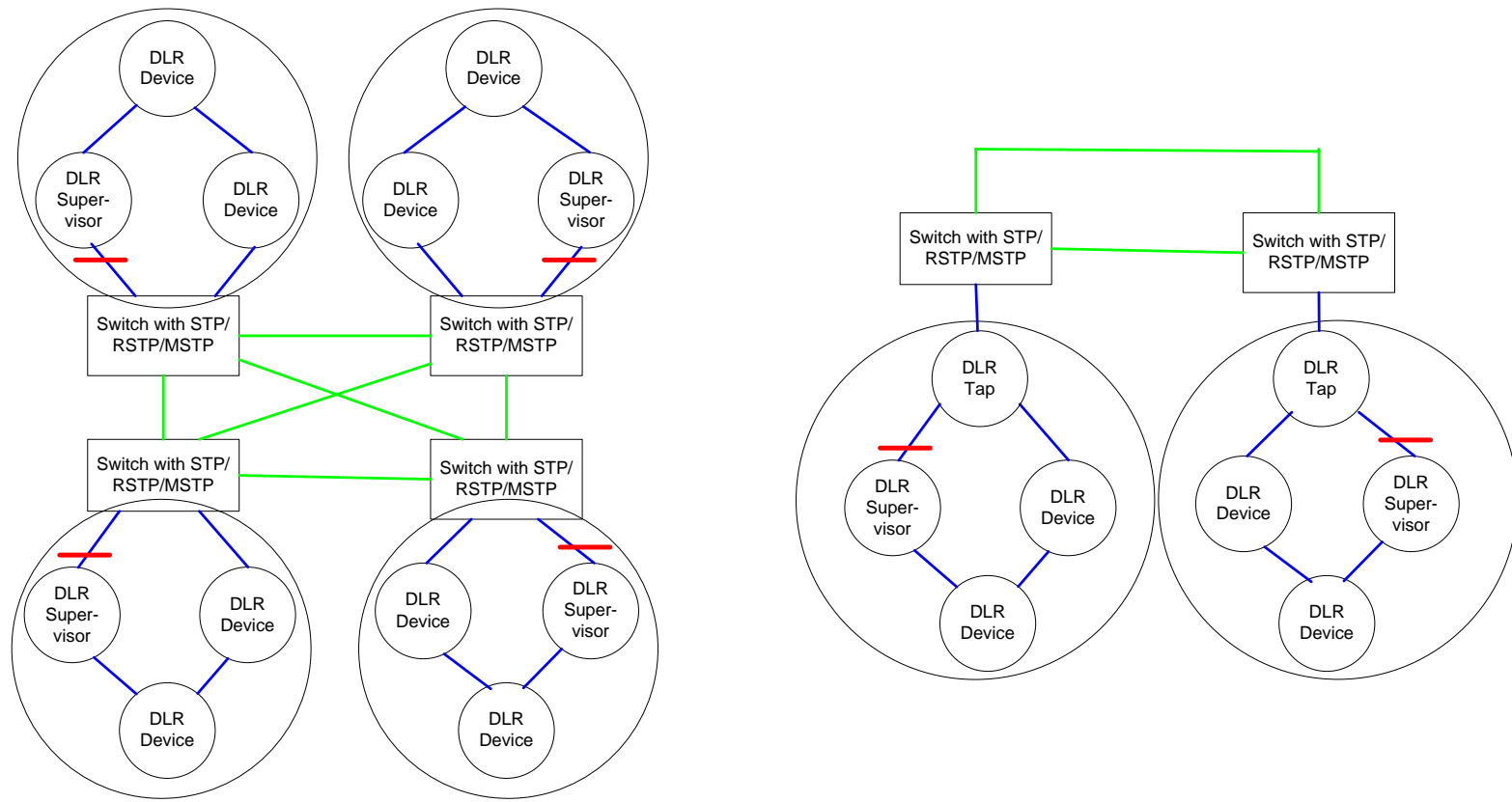

# Supported Topologies (contd.)

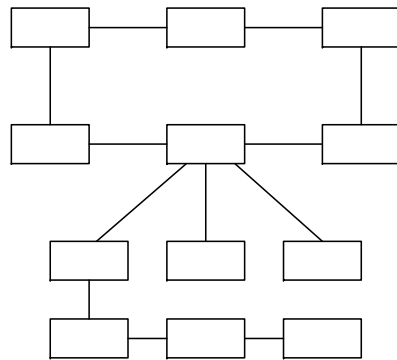

Hybrid Ring, Star and DaisyChain

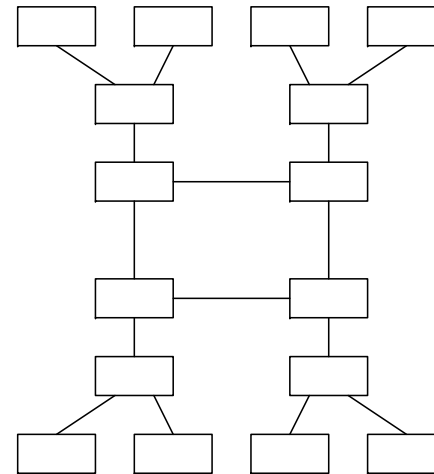

Ring of Stars

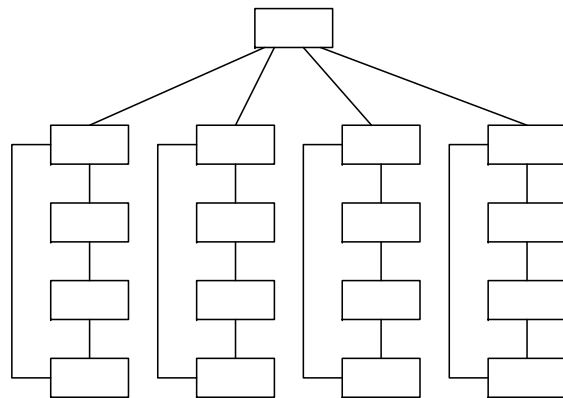

Star of Rings

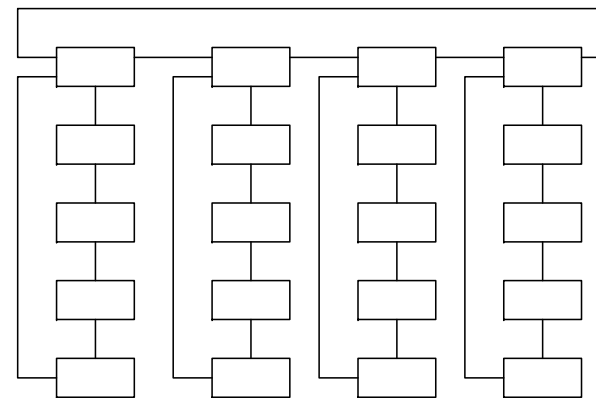

Ring of Rings

# DLR Network Guidelines

- ▶ Use multiple smaller rings interconnected through Taps/Managed switches
  - More fault tolerant than a single large ring
  - Higher performance than a single large ring
- ▶ Configure at least one supervisor per ring before closing each ring
- ▶ Unmanaged switches/devices should only be connected to ring through Taps/Managed switches
- ▶ Managed switches require special configuration to be directly on ring
- ▶ Subject to certain performance limitations



# Summary of DLR Unique Features

- High performance
- Multiple ring supervisors
- Fast and slow (Beacon-based and Announce-based) ring nodes can coexist on the same network
- Allows connection of devices not supporting the DLR protocol in ring