

Industrial Fieldbus Standards Update

Bob Lounsbury
Principal Engineer
Rockwell Automation

Presented at the ODVA
2007 CIP Networks Conference & 12th Annual Meeting
September 18-20, 2007
Englewood, Colorado USA

Abstract

This paper will cover the current state of related standards that effect DeviceNet, EtherNet/IP and ControlNet. Last year ISO/IECSC25C published the first international standard supporting Industrial Ethernet networks titled, *“Information Technology- Generic cabling –Industrial Premises”*. This year it is projected that two more standards will publish, titled *“Digital data communications for measurement and control-Part 5: Installation for communications networks in industrial control systems”* and *“Telecommunications Infrastructure Standard for Industrial Premises”*. One of these standards provides installation guidance for DeviceNet, EtherNet/IP and ControlNet. All of these standards have a direct impact on EtherNet/IP networks. This paper will cover the highlights of each standard and release schedules.

Definition of Terms

ISO/IEC, IEC, ControlNet.

References

ISO/IEC24702, IEC 61918, IEC 61784-2, TIA 1005

Introduction

Open standards are important for the promotion and adoption of networks and technology. The task of Standardizing of Ethernet in the industrial area has become a major activity within the national and international community. Further expansion of DeviceNet™ and ControlNet™ into the international standards has once again has come to the forefront. This paper will discuss the current state of the national and international standards with respect to ODVA physical layers including cabling and components.

ODVA has been a leader in the publishing of industrial Ethernet standards and planning and installation guides. Since the release of EtherNet/IP™, v1.0 in 2001 many national and international standards organizations have either released or are about to release standards for industrial Ethernet. Figure 1 shows the relationship of these standards.

Figure 1: Cabling Standards

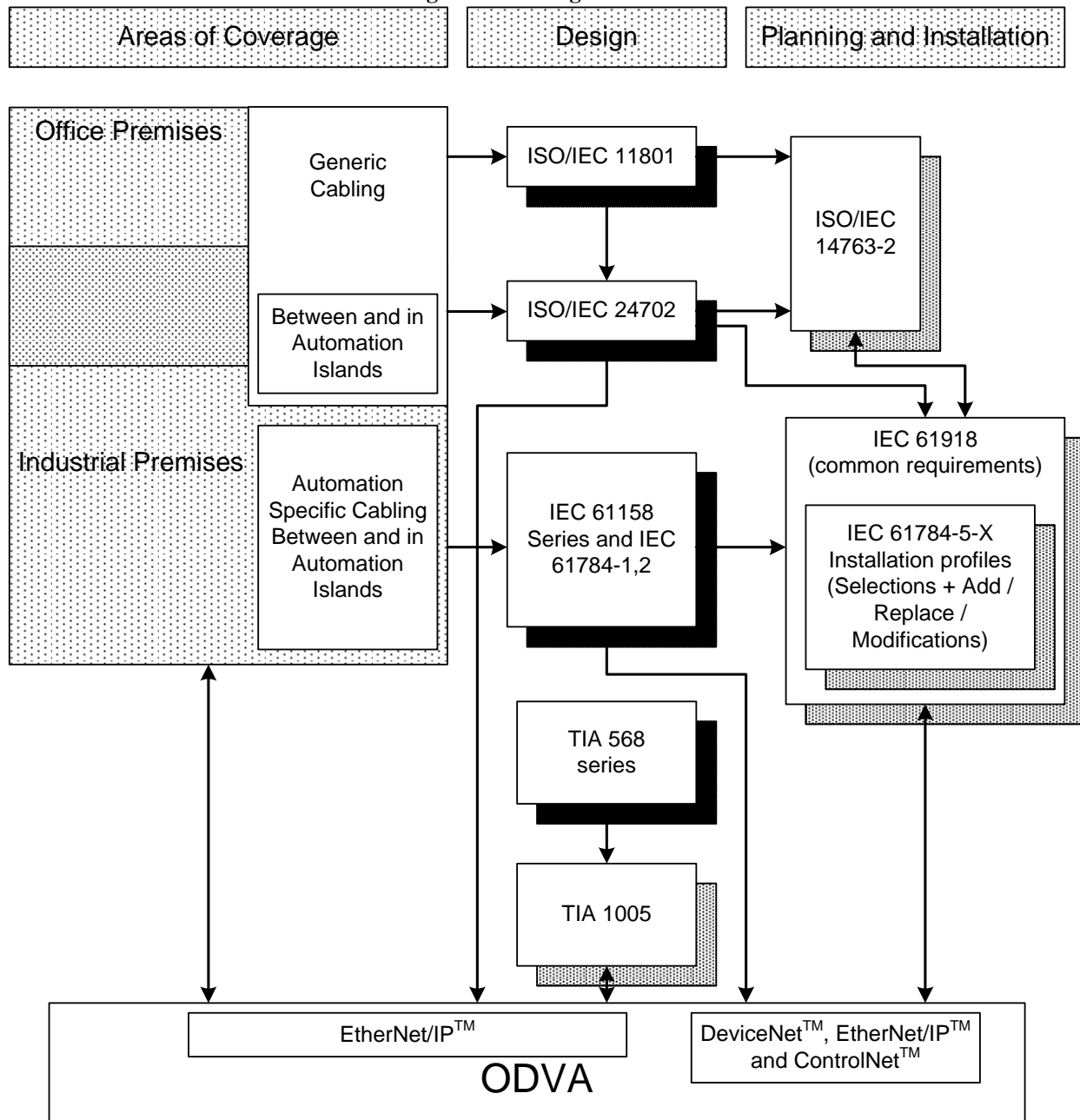

ISO/IEC 11801 and TIA 568 series standards were written several years ago to support Generic Telecommunications communications systems for commercial buildings. TIA 568 series is made up of several standards. TIA 568B.1 describes the requirements for cabling within and around the office building. TIA 568B.2 details the requirements and testing for the components used in TIA 568B.1. Additionally, there are two other standards that complete the requirements for premise wiring, TIA 569, pathways and spaces and lastly J-STD-607A, grounding and bonding.

These standards are in their maintenance phase and are currently open for the addition of Category CAT 6A in support of requirements for PoE+ and 10G up to 600MHz. TIA 568 series and ISO/IEC 11801 are the foundation for the industrial Ethernet standards. ISO/IEC 24702 was released in Fall of 2006 and is the first international standard to be released dealing with Generic Telecommunications in the industrial spaces. This standard provides cabling requirements for industrial premises. The equivalent national standard TIA 1005 will follow late this year. Both ISO/IEC 24702 and TIA 1005 will allow for more flexible channel designs such as 82 meter patch cords and M12-4 connectivity using 2 pair cables. Table 1 provides a summary of the relevant performance and installation standards that have a direct impact on CIP networks. The majority of these standards provide the foundation for EtherNet/IP.

Table 1: Standards Summary

Standard	Name	Release Date	Description
TIA 568 series	Commercial Building Telecommunications Cabling Standard	April 2001, revisions in progress	Cabling component requirements and network performance. Basis for the industrial standard
TIA 1005	Industrial Telecommunications Cabling Standard	Release 1 st Q 2008	Cabling component and performance for industrial networks up to and including machine areas, less fieldbus
ISO/IEC 11801	Information Technology Generic cabling for customer premises	Release 2002 – 2009, currently under revision addendums CAT 6a	Cabling component requirements and network performance, basis for industrial standard
ISO/IEC 24702	Information Technology Generic cabling - Industrial premises	Initial release nov 2006 NWP to add POF	Cabling and component for industrial networks up to and including machine areas less fieldbus.
ISO/IEC14673-n	Installation for Information Technology	Currently under revision and re-organization, addition of Industrial premises	May conflict with IEC 61918 and IEC 61784-5-n
IEC 61918	Industrial Communications Networks – Installation of communications networks in industrial premises	Initial release expected Dec, 2007	Umbrella document for fieldbus installation profiles defined in IEC 61784-5-n
IEC 61784-5-n	Industrial Communications Network-Profiles Part5-2: Installation of fieldbuses-installation profiles for CPF-2	Initial release expected Dec, 2007	Profiles for DeviceNet, EtherNet/IP and ControlNet and other non-CIP based profiles
IEC 61784-1-n	Digital data communications for measurement and control Pt1 Profile sets for continuous and discrete manufacturing relative to fieldbus use in industrial control systems	Release 2003-2005, currently under revision with release late 2007	Upper layers for ControlNet (CIP)
IEC 61158	Digital data communications for measurement and control-fieldbus for use in industrial control Pt 2 Physical layer specification and service definition	Release 2003 – 2005 Currently under revision with release late this year	ControlNet, EtherNet/IP and other fieldbus (DeviceNet is not currently part of this standard)
IEC 62026-3	Low-voltage switchgear and control gear-Controller-device interfaces-Pt 3 DeviceNet	Release 2000-2007	International standard for DeviceNet. Support for this standard is moving into SC65C's domain

Why these standards are important

If one is designing cabling components or networks for commercial or industrial telecommunications services (including automation) an understanding of ISO/IEC 11801, TIA 568 series, ISO/IEC 24702 and TIA 1005 standards is mandatory. Further if one is planning and installing a network either for generic telecommunications or automation a thorough understanding of one or more of the installation standards such as ISO/IEC 14763-2, IEC 61918 and IEC 61784-5-X is mandatory. Ethernet is an integral part of all these standards, however for fieldbus applications other than Ethernet, only IEC 61158 and 61784-1, IEC 61918 and IEC 61784-5-X apply. Because EtherNet/IP is based on the standard telecommunications infrastructure, network designer needs to understand the basic concepts of the relevant generic standard and the additional requirements for industrial use that are detailed in ISO/IEC 24702 and the soon-to-be-released TIA 1005. The industrial pathways and spaces will be provided in an addendum to TIA 1005 that will be released soon after TIA 1005.

What is common between the standards

MICE: There is one concept that is becoming common within the standards and that is the concept of Mechanical, Ingress, Climatic and Environmental (MICE). This concept helps component designers to choose materials and network planners with component selection. Later this year, the MICE concept will be proposed for adoption by ODVA. MICE is a tool to help the designer and installer select the correct components or mitigation for a given environmental area. This concept has three environmental classifications (levels), Commercial, Light Industrial and Industrial. In general, the industrial is the harshest environment. An environment will be a combination of parameters potentially crossing all classifications.



Major Parameters	Commercial	Light Industrial	Industrial
Mechanical	M ₁	M ₂	M ₃
Ingress	I ₁	I ₂	I ₃
Climatic	C ₁	C ₂	C ₃
Electromagnetic	E ₁	E ₂	E ₃

TCL: The standards committees have recognized the importance of channel balance for noise immunity and are now focusing on enhanced Transverse Conversion Loss (TCL) and Equal Level Transverse Conversion Transfer Loss (ELTCTL) values Cat 5e, Cat 6 and Cat 6A Unshielded Twisted Pair (UTP) cables. Recognizing that the noise levels are greater in a MICE_{2,3} environment, ISO/IEC 24702 has greater values for channel balance in these areas as shown in Figure 2. The like has been defined for Shielded Twisted Pair (STP) cables in the form of coupling attenuation.

Figure 2: TCL for Industrial Class D Channels

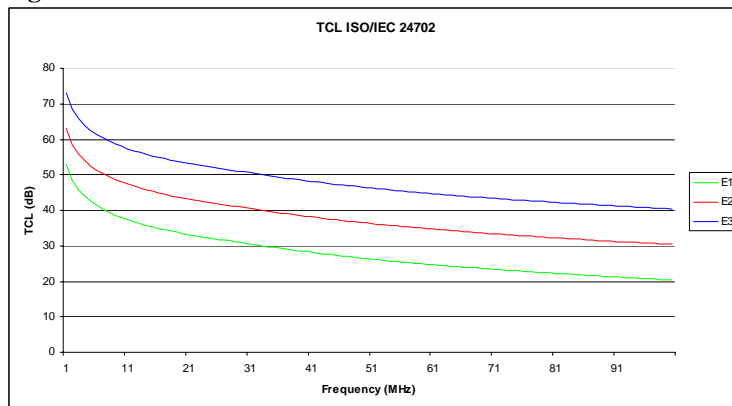

Other standards related activities

Figure 1 shows that IEC 61918 and IEC 61784-5, are installation related standards. These standards are being written to support DeviceNet, ControlNet as well as EtherNet/IP. CompoNet was not included as this new addition to the ODVA standard came past the closing date for Revision 1 of these standards. In addition, IEC 61784-5 also supports other communications networks such as ProfiNet, ProfiBus and InterBus. The standard is organized into profiles where each organization is called a Communications Family and each family contains one or more communications profiles, as shown in Figure 3. This standard will reopen in the maintenance phase after January 2008. At that time additional communications profile families and/or communications profiles can be added.

Figure 3: IEC 61784-5 Installation Profiles

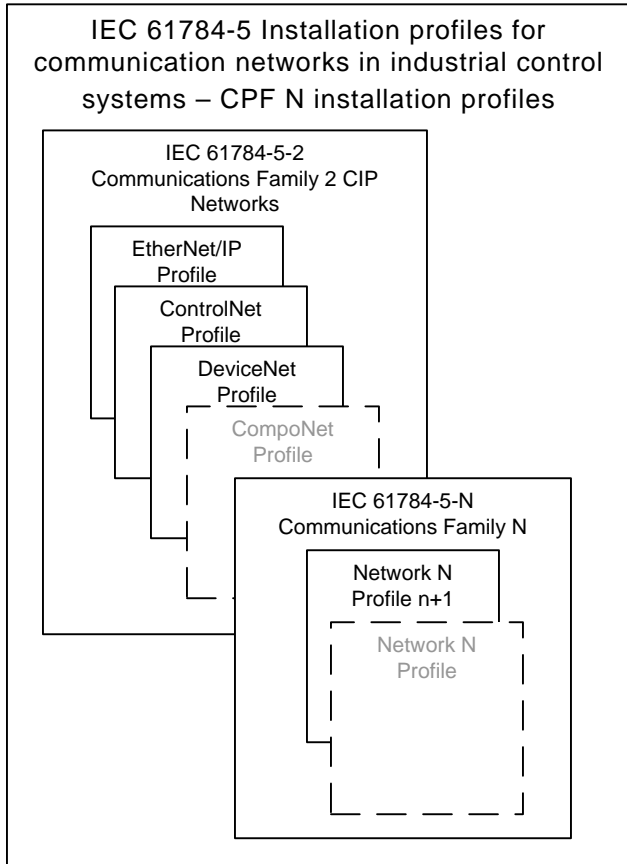

Schedule of standards release and maintenance

The first non consortia industrial standard to be released that supports industrial Ethernet applications was ISO/IEC 24702. ISO/IEC 24702 deals with the performance requirements for cabling components and cabling. The second to follow will be the installation profiles under IEC 61918 and IEC 61784-5 series. Table 2 provides a summary of standards activity. Currently ANSI/TIA/EIA is restructuring the Telecommunications Infrastructure standards into a series under TIA 568 C structure. Following the release of TIA 1005, this standard will be reformatted to fit under TIA 568 C. series. The common aspects of TIA 568-B and TIA 569 and TIA 1005 will be combined under TIA 568-C.0. TIA 568 C.1 will contain what is essentially in TIA 568-B.1 less the common parts and TIA 568-C.2 will contain what is in TIA 568-B.2 less the common parts which will become TIA 568-C.0. The addendums for each of these standards including Cat 6a will be distributed into the appropriate areas of the new structure.

Table 2: Standards time table

Standard	Release Date	Update
ISO/IEC 24702	October 2006	5 years POF addendum 2008
IEC 61784-5	December 2007	2 years
IEC 61918	December 2007	2 years
TIA 1005	December 2007	5 years
ODVA Chapter 8 Rev 2	November 2007	Continuous
STD-J 607 A	TBD	Currently under revision

References

ISO/IEC24702, IEC 61918, IEC 61784-5-2, TIA 1005, STD-J 607

DeviceNet, DeviceNet Safety, CIP, CIP Motion, CompoNet, CIP Safety and CIP Sync are trademarks of ODVA. EtherNet/IP is a trademark of ControlNet International under license by ODVA. Other trademarks are property of their respective owners.

The ideas, opinions and recommendations expressed herein are intended to describe concepts of the author(s) for the possible use of CIP Networks and do not reflect the ideas, opinions, and recommendation of ODVA per se. Because CIP Networks may be applied in many diverse situations and in conjunction with products and systems from multiple vendors, the reader and those responsible for specifying CIP Networks must determine for themselves its suitability and the suitability of ideas, opinions, and recommendations expressed herein for intended use.

Copyright ©2007 Open DeviceNet Vendor Association, Inc. (ODVA). All rights reserved.

For permission to reproduce excerpts of this material, with appropriate attribution to the author(s), please contact ODVA on:

TEL +1 734-975-8840
FAX +1 734-922-0027
EMAIL odva@odva.org
WEB www.odva.org