

SPECIFYING CABLES AND CONNECTORS FOR INDUSTRIAL ETHERNET/IP™ NETWORKS

Bob Lounsbury
Principal Engineer
Rockwell Automation

Presented at the ODVA
2007 CIP Networks Conference & 12th Annual Meeting
September 18-20, 2007
Englewood, Colorado USA

Abstract

This white paper is arranged to help the user select cabling based on the, application, the environmental conditions and mechanical requirements. It is true that any Category 5 or higher cable will support 10/100BaseT traffic. It is not true that a Category 5 cabling will provide the level of performance needed to survive long term in a harsh high noise industrial environment. One of the most important factors in selecting the correct cable is having a thorough understanding the environment where the cables will installed. The planner should already understand the application needs (ie 10Mb/s, 100Mb/s...) and will need to focus on environmental and mechanical aspects of the cabling. To aid in understanding the environment, this paper is based on a concept called MICE (Mechanical, Ingress, Climatic/Chemical and Electromagnetic). Cabling attributes and performance can be defined for the industrial areas based on the environments and conditions as defined by MICE severity levels, called classifications. This paper will focus on the minimum cabling requirements to provide adequate performance in areas of E₁, E₂ and E₃ electromagnetic interferences. Harsh attributes such as Mechanical, Ingress and chemical (M,I,C) will be relatively straight forward. Given this, it is not adequate to simply specify cabling as Cat 5e, Cat 6, shielded or unshielded.

Keywords

MICE, UTP, STP, Long Term, Survive, Category

Introduction

This document will help the reader to select connectivity components based on zero mitigation. Mitigation is a method of converting one environment into a less harsh environment. Further this cable selection white paper, provides a selection process for the selection of cabling components to minimize performance degradation due to effects from EMC.

About MICE

MICE is a method of categorizing the environment that supports three levels called classifications. The three levels are; $M_1I_1C_1E_1$, $M_2I_2C_2E_2$ and $M_3I_3C_3E_3$. The three classifications can be mapped to the following severity levels; 1=Office, 2=Light Industrial and 3=Industrial. The industrial areas can be generalized into four typical areas, factory floor, work area, machine area and telecommunications room/enclosure.



Major Parameters	Commercial	Lt Industrial	Industrial
Mechanical	M ₁	M ₂	M ₃
Ingress	I ₁	I ₂	I ₃
Climatic	C ₁	C ₂	C ₃
Electromagnetic	E ₁	E ₂	E ₃

Each increasing severity level is harsher. Generally an area does not have the same level for all categories (Mechanical, Ingress, Climatic/Chemical and Electromagnetic). For example a machine may be in an area where the vibration is very high, hence M₃, the area may be free of dust and liquids, hence I₁, the temperatures may be high, hence C₃ and the electromagnetic levels are low hence E₁. The upper limits for each classification is described in the MICE **Error! Reference source not found.** below. Figure 1 provides a brief overview of the sub categories for each category of M,I,C,E.

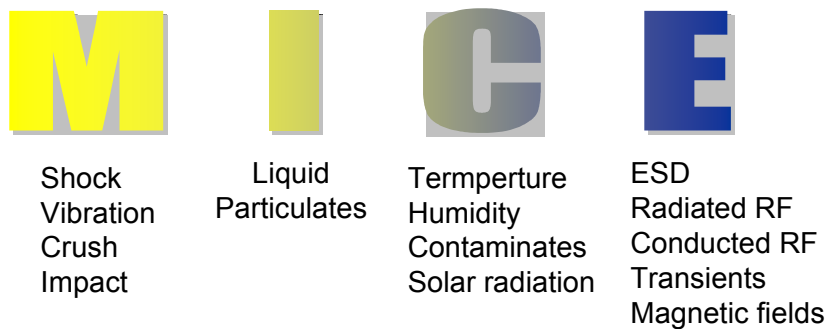

Figure 1: MICE Concept

This concept is a formal approach used by planners of systems to systematically classify their areas thus helping to define the materials needed to build the network. Most industrial facilities can be defined by four areas as shown in Figure 2. These areas are Machine area (automation island), the work area, factory floor and telecommunications closet/enclosure/room. The telecommunications closet or enclosure houses commercial rated products and therefore may require HVAC to maintain a $M_1I_1C_1E_1$ environment. Table 1 shows the typical MICE classifications (levels) for each area within the factory.

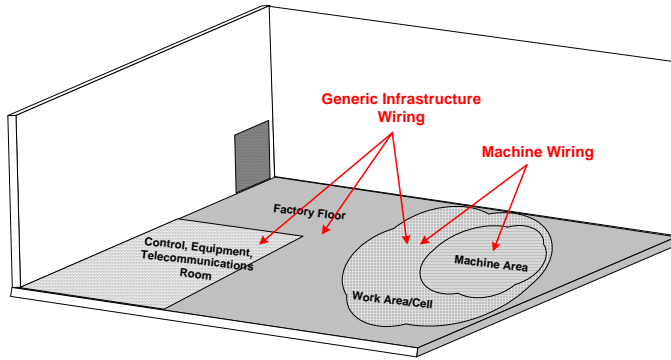

Figure 2 :Typical Factory Areas

The machine area is surrounded by the work area and the machine and work area is generally located on the factory floor. A factory floor may consist of many machine areas and work areas. The converse is also true where the machine area covers the entire factory floor, thus one large machine or process such as tank farms and food processing.

Typical MICE Classification and Industrial Areas			
Area	Factory Floor	Work area	Machine Area
Typical Classification (MICE)	1&2	2	2&3

Table 1 : Classification of Industrial Areas

Guidance on determining your MICE Classifications

Keeping the MICE concept in mind, each area that the cabling system is to be installed in or traverses through must be considered. For example, if the cable passes over a furnace whereby the temperature in the plenum area above the furnace is greater than 60°C, then the cabling components must be selected to provide performance at this temperature.

The network designer should evaluate the installation coverage area completely. Decisions should be made to provide mitigation in areas in that exceed the MICE limits . Further mitigation should be considered in areas in which cost savings of the installation can be realized. For example in the previous section I spoke about the plenum area above an industrial furnace where the cabling needs to pass through. Rather than use expensive high temperature cabling components in this area, the designer may choose to provide heat deflectors to protect the cables or simply re-routed giving separation from the heat.

The complete MICE table is below in **Error! Reference source not found.**. The planner should familiarize his/her self with the table. Each area where the cabling is to be installed can be categorized and classified using the MICE table. Materials and/or mitigation can then be determined from the classification process for all components. For examples on how to use the MICE table to select components an/or mitigation techniques the reader should obtain a copy of the “MICE Tutorial” available on the ODVA web site or through ISO/IEC as a technical service bulletin.

Mechanical	M₁	M₂	M₃
Shock/bump			
Peak acceleration	40 ms ⁻²	100 ms ⁻²	250 ms ⁻²
Vibration			
Displacement amplitude (2-9 Hz)	1,5 mm	7,0 mm	15,0 mm
Acceleration amplitude (9-500Hz)	5 ms ⁻²	20 ms ⁻²	50 ms ⁻²
Tensile force	See Note 1	See Note 1	See Note 1
Crush	45 N over 25 mm (linear) min.	1100 N over 150 mm (linear) min.	2200 N over 150 mm (linear) min.
Impact	1 J	10 J	30 J
Bending, flexing and torsion	See Note 1	See Note 1	See Note 1
Ingress	I₁	I₂	I₃
Particulate ingress (dia. max)	12.5 mm	50 µm	50 µm
Immersion	None	Intermittent liquid jet <=12,5 l/min >= 6,3 mm jet > 2,5 m distance	Intermittent liquid jet <=12,5 l/min >= 6,3 mm jet > 2,5 m distance and immersion (<=1 m for <=30 minutes)
Climatic and Chemicals	C₁	C₂	C₃
Ambient temperature	-10° C to +60° C	-25° C to +70° C	-40° C to +70° C
Rate of change of temperature	0,1° C per minute	1,0° C per minute	3,0° C per minute
Humidity	5% to 85% (non-condensing)	5% to 95% (condensing)	5% to 95% (condensing)
Solar radiation	700Wm ⁻²	1120 Wm ⁻²	1120 Wm ⁻²
Liquid pollution			
Contaminants			
Sodium chloride (salt/sea water) (µg/g)	0	<0,3	<0,3
Oil (µg/g)	0	<5,0	<500
Sodium stearate (soap)	None	5% aqueous non-gelling	>5% aqueous gelling
Detergent	None	ffs	ffs
Conductive materials in solution	None	Temporary (condensation)	Present
Gaseous pollution	Mean/Peak (Concentration X 10 ⁻⁶)	Mean/Peak (Concentration X 10 ⁻⁶)	Mean/Peak (Concentration X 10 ⁻⁶)
Hydrogen sulphide	<0,003/<0,01	<0,05/<0,5	<10/<50
Sulphur dioxide	<0,01/<0,03	<0,1/<0,3	<5/<15
Sulphur trioxide (ffs)	<0,01/<0,03	<0,1/<0,3	<5/<15
Chlorine wet (>50% humidity)	<0,0005/<0,001	<0,005/<0,03	<0,05/<0,3
Chlorine dry (<50% humidity)	<0,002/<0,01	<0,02/<0,1	<0,2/<1,0
Hydrogen chloride	-/<0,06	<0,06/<0,3	<0,6/3,0
Hydrogen fluoride	<0,001/<0,005	<0,01/<0,05	<0,1/<1,0
Ammonia	<1/<5	<10/<50	<50/<250
Oxides of Nitrogen	<0,05/<0,1	<0,5/<1	<5/<10
Ozone	<0,002/<0,005	<0,025/<0,05	<0,1/<1
Electromagnetic	E₁	E₂	E₃

Electrostatic discharge – Contact (0,667 μ C)	4 kV	4 kV	4 kV
Electrostatic discharge – Air (0,132 μ C)	8 kV	8 kV	8 kV
Radiated RF - AM	3V/m @ 80-2000MHz 3V/m @ 1400-2000MHz 1V/m @ 2000-2700MHz	3V/m @ 80-2000MHz 3V/m @ 1400-2000MHz 1V/m @ 2000-2700MHz	10V/m @ 80-1000MHz 3V/m @ 1400-2000MHz 1V/m @ 2000-2700MHz
Conducted RF	3V @ 150kHz-80MHz	3V @ 150kHz-80MHz	10V @ 150kHz-80MHz
EFT/B	500 V	1000 V	1000 V
Surge (transient ground potential difference) - Signal, line to earth	500V	1000V	1000 V
Magnetic Field (50/60 Hz)	1 Am ⁻¹	3 Am ⁻¹	30 Am ⁻¹
Magnetic Field (60-20000Hz)	ffs	ffs	ffs
Bump: the repetitive nature of the shock experienced by the channel shall be taken into account.			

NOTE 1: This aspect of environmental classification is installation-specific and should be considered in association with IEC 61918 (in preparation)

Details of Environmental Classification

Table 2 : MICE Table

Summary of the Steps in Selecting Cables.

- 1) Determine the channel bandwidth requirements to suit the applications for example Channel Class or Category, see Table 3 below.
- 2) Determine cable type (shielded or unshielded)
- 3) Determine additional electrical attributes needed based on E₁, E₂ or E₃ noise types and levels.
- 4) Two pair or four pair cabling
- 5) Determine the M,I,C severity levels where the cables will be deployed
- 6) Determine additional attributes for the cabling, for example high flex, weld splatter etc.

Each of the 6 steps will be described in detail in the following paragraphs.

To help clarify each step, a cable specification will be determined based on an example justification. The example will can be found in a table at the end of each step as shown in the table below.

Example Cable Specification					
Step 1 Channel	Step 2 Cable type	Step 3 EMI Performance	Step 4 2/4 pair	Step 5 M,I,C, severity classifications	Step 6 Additional mech. attributes
<i>Justification</i>	<i>Justification</i>	<i>Justification</i>	<i>Justification</i>	<i>Justification</i>	<i>Justification</i>
<i>Specification</i>	<i>Specification</i>	<i>Specification</i>	<i>Specification</i>	<i>Specification</i>	<i>Specification</i>
Specifications in addition to TIA 568B and ISO/IEC11801					

There are a total of 6 steps in defining the correct cable(s) for the application(s) and environment(s). A network planner may have a need to specify any where from 1 or more cables dependant on the applications and number of environmental areas within the communications coverage area. The final number of cables will be based on cost and complexity of the network and level of mitigation. For example cost may not be as important as having one cable construction in the entire system. In this case a supper cable, “one cable does” all may be specified. The planner may choose to reduce the number of cables needed by protecting the cables through mitigation techniques (Isolation and Separation). Any special attributes (defined in step 6 below) such as high flex is certain to increase the cable count. Regardless of how many different cables are identified, the planner must consider the environment.

Below are the 6 steps that a planner can use to develop a cable specification. In general all cabling and cabling components need to be complaint with TIA 568B and or ISO/IEC 11801 with the additional requirements.

The additional requirements below are consistent with requirements of ISO/IEC 24702 *Information Technology- Generic cabling –Industrial Premises*

Step 1) Channel Bandwidth

The channel bandwidth will be the easiest to determine. Table 3 provides channel bandwidth and cabling Category based on data rates.

Data Rate	Minimum Category to support data rate TIA 568B.1	Recommended Category	Channel Class ISO/IEC 11801	Channel Bandwidth ISO/IEC 11801
10Mb/s	Cat 3	Cat 5	Class C	16 MHz
100Mb/s	Cat 5e	Cat 5e, Cat 6	Class D	100 MHz
1Gb/s 10Gb/s	Cat 6	Cat 6 and Cat 6a	Class E	250 MHz

Table 3: Channel Bandwidth versus Cabling Categories

For example, If the channel needs to support 10/100Mb/s, then a minimum of Cat5e cabling and Class D (100MHz) channel is required. To provide additional margin in the channel design Category 6 is recommended.

Important: It is not recommended to mix category components in the same channel.

Using category 5e components and constructing the channel in accordance with the reference implementations as defined in ISO/IEC 11801 a Class D channel with a 100Mb/s bandwidth is guaranteed by the standard. The reference implementations allow for a maximum of 4 connections in a channel. The following Figure 3, Figure 4 and Figure 5 are reference implementations from ISO/IEC 11801.

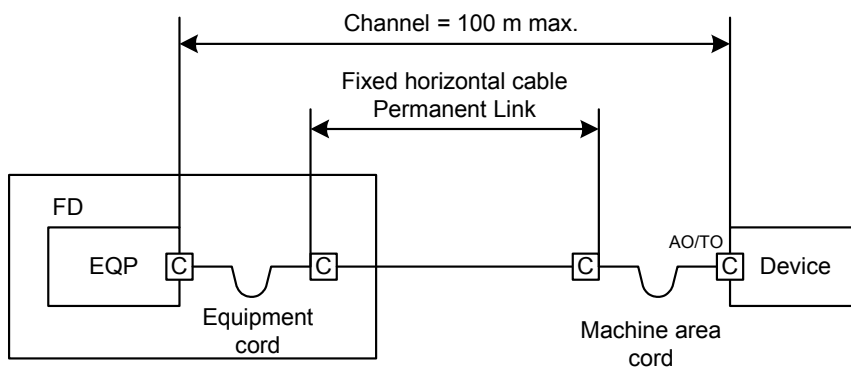

EQP = Equipment ie; switch, router
 FD = Floor Distributor
 AO = Automation Outlet
 TO = Telecommunications Outlet

Figure 3 : Cross Connect AO/TO Model

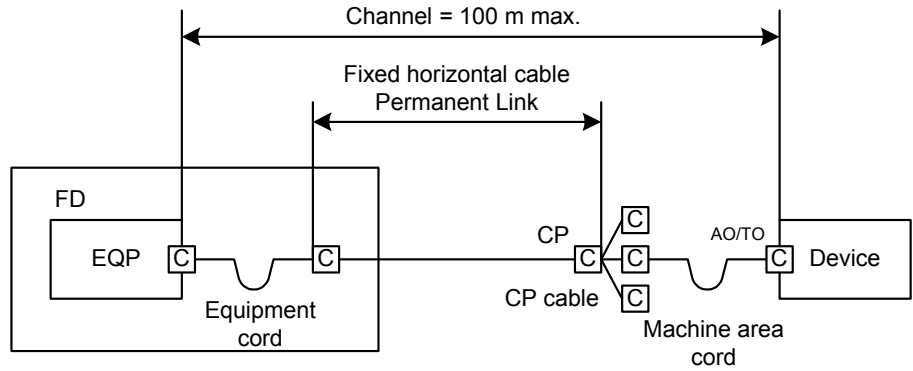

EQP = Equipment ie; switch, router
 FD = Floor Distributor
 AO = Automation Outlet
 TO = Telecommunications Outlet
 CP = Consolidation Point

Figure 4 : Cross Connect AO/TO with CP Model

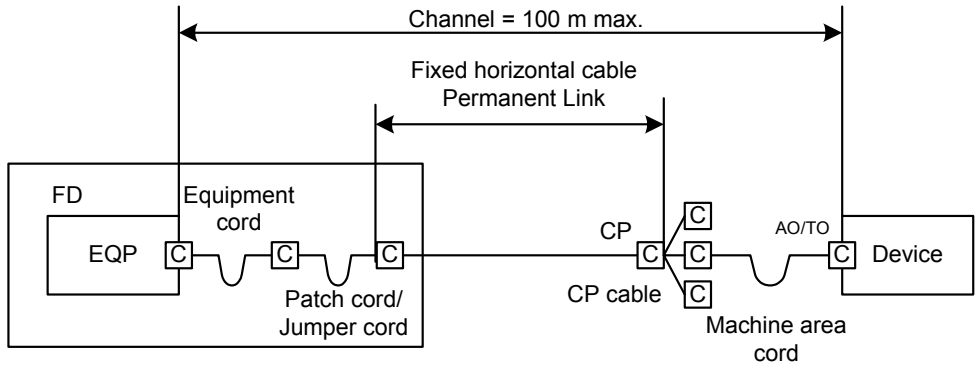

EQP = Equipment ie; switch, router
 FD = Floor Distributor
 AO = Automation Outlet
 TO = Telecommunications Outlet
 CP = Consolidation Point

Figure 5 : Cross connect CP Model

Example Cable Specification					
Step 1 Channel	Step 2 Cable type	Step 3 EMI Performance	Step 4 2/4 pair	Step 5 M,I,C, severity classifications	Step 6 Additional mech. attributes
My application requires 10/100mb/s					
Cat6 Class D					
Specifications in addition to TIA 568B and ISO/IEC11801					

Step 2) Selecting shielded or unshielded media

Cables with shields are sometimes referenced as ScTP, FTP, STP etc. The differences in this cables is construction of the shield and naming preferences. Throughout this document they will be referenced in a generic sense as “STP”. Cables without shields are usually referenced as UTP cables, meaning Unshielded twisted pair cables. Likewise throughout this document they will be referenced as UTP cables. It is important to note that both cables (STP and UTP) are balanced 100 ohm twisted pair cables. There are a number of factors in determining if shielded cabling or unshielded should be used. Some geographical areas mandate that STP cabling be used. Some companies have policies regarding the use of STP or UTP cabling. Putting these aside there are technical reasons one or the other should or should not be used. This paper will focus on the technical aspects of selecting STP cabling over UTP cabling.

Shields help to reduce noise coupled to the balanced cables by providing a faraday shield around the conductors. However this is countered in some cable designs by using poorly balanced cable pairs. Shields can carry ground currents due to ground offsets with in the building grounding system. These currents at worse case can cause equipment damage. At the least, the currents can be disruptive to the network communications. EtherNet/IP reduces the chance of ground loops by isolating the shield at one end of the channel from ground. This is done through the use of an RC between the shield and local node ground connection. The RC is always in the device end and not at the switch end. The switch end of a shielded channel is always grounded if the switch is grounded. If properly grounded, shielded cables are useful in reducing communications error rates. The construction of a shielded cable is more complex and there for not as robust in flexing applications as a unshielded twisted pair cable (UTP). The following Table 4 below can be used as a guide in determining if shielded cables are appropriate.

General Guidance for Selecting Media Type (STP or UTP)		
Use Shielded	Use UTP or other Media	Comments
	Poor building grounds, any locations where the ground off sets are > 1V in the cabling coverage area.	Fiber may be used as an alternative to UTP
Installations in conduit		UTP acceptable if transmission performance is maintain ie; RL, FEXT, NEXT, Attenuation (see note)
When $EFT > E_1$		See Step 3 for additional guidance and use of UTP
Conducted or radiated EMI is > E_3		
High ESD discharge E_1 or greater		Fiber is also acceptable
	High flex applications	Some shielded constructions are ok (braided shields)
	Surge > E_1	

Table 4 : Selecting ScTP or UTP Cables

NOTE: Transmission performance is the ability to meet a minimum level of transmission related parameters such as Return Loss (RL), Near End Cross Talk (NEXT) and Far End Cross Talk (FEXT) as required by TIA 568 series and ISO/IEC 11801 series standards. Meeting these parameters assures that the channel will provide a minimum required support for the application based on bandwidth.

- Shielded connectors are mandatory if shielded cables are used.
- Shields shall be terminated in accordance with the ODVA Planning and Installation Manual.
- Mitigation may be used to solve any of the issues above, allowing the cable type to be arbitrary. For example, adding equalizing conductors in parallel with STP cables can be used to reduce the ground potential differences between two points that the channel spans.

Example Cable Specification					
Step 1 Channel	Step 2 Cable type	Step 3 EMI Performance	Step 4 2/4 pair	Step 5 M,I,C, severity classifications	Step 6 Additional mech. attributes
<i>Application requires 10/100mb/s</i>	<i>Poor bldg g rounds</i>				
<i>Cat6 Class D</i>	<i>UTP</i>				
Specifications in addition to TIA 568B and ISO/IEC11801					

Step 3) Additional Electrical Requirements (critical)

This is one of the most important steps in defining the cable. The planner has to have an understanding of the noise mechanisms, noise levels and sources to accurately define the noise performance required of the cabling. The difficulty in doing this is that the planner may not have a way to quantify the noise levels. The following tables will help to empirically determine the ingress mechanism and level from the noise source while mapping into MICE $E_{1,2,3}$ classifications. Using left hand column of Table 5 below find the noise generating source(s) where the cabling will be installed. Knowing the distance of the cable from the source, determine the E classification (E_1 , E_2 or E_3). From Table 6 below again find the noise generating source(s) in the left hand column and find the ingress mechanism. Understanding the noise ingress mechanisms will help not only in the selection of the cables but also in understanding mitigation and installation techniques.

Noise Generating Device	Distance from cabling	“E” Classification
Contactor Relay	< 0.5 m	E ₂
	> 0.5 m	E ₁
Transmitters (<1 W)	< 0.5 m	E ₃
	≥ 0.5 m	E ₁ or E ₂
Transmitters (1 W to 3 W)	< 1.0 m	E ₃
	≥ 1.0 m	E ₁ or E ₂
Transmitters (TV Radio. mobile base station)	< 0.3 km	E ₃
	≥ 0.3 km	E ₁ or E ₂
High HP motors (50 HP or greater)	< 3 m	E ₃
	> 3 m	E ₁
Drive Controllers	< 0.5 m	E ₃
	0.5 < 3 m	E ₂
	> 3 m	E ₁
Induction Heating < 8 MW	< 0.5 m	E ₃
	0.5 < 3 m	E ₂
	> 3 m	E ₁
Resistance Heating	< 0.5 m	E ₂
	> 0.5 m	E ₁
Fluorescent Lights	< 0.15 m	E ₃
	> 0.15 m	E ₁ or E ₂
Thermostatic Switches 110 V to 230 V	< 0.5 m	E ₂ - E ₃
	> 0.5 m	E ₁

Table 5 : Noise Generating Devices VS “E” Classification

Noise Generating Device	Noise	Coupling mechanism
Electric Motors	Surge and EFT	Local Ground. Conducted
Drive Controllers	Conducted and Surge	Local Ground. Conducted
Relays and Contactors	EFT	Radiated. Conducted
Welding	EFT. Induction	Radiated Magnetic
RF Induction Welding	Radio Frequency	Radiated. Conducted
Material handling (paper/textile)	ESD	Radiated
Heating	EFT	Local Ground. Conducted. Radiated
Induction Heating	EFT. Magnetic	Local Ground. Conducted. Radiated
Radio Communications	Radio Frequency	Radiated

NOTE: for an explanation of EFT and ESD see the glossary of terms at the end of this document.

Table 6 : Noise Generating Devices VS Coupling Mechanism

After determining the E classification and the ingress mechanism from Table 5 and Table 6 respectively and knowing the channel bandwidth (Class D,E or F) from step 1. look up the TCL. ELTCTL and coupling attenuation for the appropriate E classification and selected cable type (UTP or STP). Tables Table 7 and Table 8 are used for UTP cables and Table 9 is used if STP cables were selected. If the coupling mechanism is through ground offsets the selection of STP may need revisited or mitigation is required. An expectable method for reducing ground offsets is by adding equalizing conductors in parallel with the communications cables see Figure 6. Note that there are other reasons to revisit the cable type selected, such as if STP cables were selected and the EFT is determined to be greater the level of E1.

Class	Frequency MHz	Environmental classification		
		E1	E2	E3
		Minimum TCL (dB) UTP Cable Types		
D	$1 \leq f \leq 30$	$53 - 15 \times \log(f)$. 40 max	$63 - 15 \times \log(f)$. 40 max	$73 - 15 \times \log(f)$. 40 max
	$30 \leq f \leq 100$	$60.4 - 20 \times \log(f)$	$70.4 - 20 \times \log(f)$	$80.4 - 20 \times \log(f)$
E	$1 \leq f \leq 30$	$53 - 15 \times \log(f)$	$63 - 15 \times \log(f)$. 40 max	$73 - 15 \times \log(f)$. 40 max
	$30 \leq f \leq 250$	$60.4 - 20 \times \log(f)$	$70.4 - 20 \times \log(f)$	$80.4 - 20 \times \log(f)$
F	$1 \leq f \leq 30$	$53 - 15 \times \log(f)$	$63 - 15 \times \log(f)$. 40 max	$73 - 15 \times \log(f)$. 40 max
	$30 \leq f \leq 600$	$60.4 - 20 \times \log(f)$	$70.4 - 20 \times \log(f)$	$80.4 - 20 \times \log(f)$

NOTE: Values above 100 MHz are for information only

Table 7 : TCL VS "E" Classification for UTP Cable Types

Class	Frequency MHz	Environmental classification		
		E1	E2	E3
		Minimum ELTCTL (dB) UTP Cable Types		
D, E and F	$1 \leq f \leq 30$	$30 - 20 \times \log(f)$	$40 - 20 \times \log(f)$	$50 - 20 \times \log(f)$. 40 max.

Table 8 : ELTCTL VS "E" Classification UTP Cable Types

Class	Frequency MHz	Environmental classification		
		E1	E2	E3
		Minimum Coupling Attenuation (dB) Shielded Cable Types		
D	$30 \leq f \leq 100$	40	50	60
E	$30 \leq f \leq 250$	$80 - 20 \times \log(f)$. 40 max.	$90 - 20 \times \log(f)$. 50 max.	$100 - 20 \times \log(f)$. 60 max.
F	$30 \leq f \leq 600$	$80 - 20 \times \log(f)$. 40 max.	$90 - 20 \times \log(f)$. 50 max.	$100 - 20 \times \log(f)$. 60 max.

NOTE: Coupling attenuation applies to maximum frequency of class. and beyond that to 1 GHz for general EMC information.

Table 9 :Coupling Attenuation VS "E" Classification Shielded Cable Types

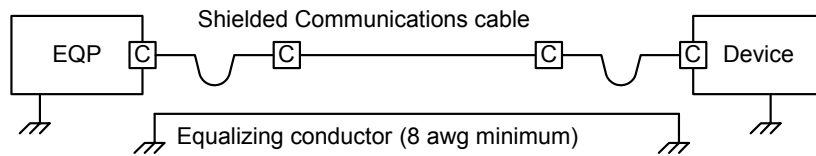

Figure 6 : Ground offset Equalizing Conductor (Equipotential)

Example Cable Specification					
Step 1 Channel	Step 2 Cable type	Step 3 EMI Performance	Step 4 2/4 pair	Step 5 M.I.C. severity classifications	Step 6 Additional mech. attributes
Application requires 10/100mb/s	Poor bldg grounds	E3 conducted			
Cat6 Class D	UTP	$TCL = 1 \leq f \leq 30. 73-15 \times \log (f). 40$ <i>max</i> $30 \leq f \leq 100. 80.4 - 20 \times \log (f)$ $ELTCTL =$ $50 - 20 \times \log (f). 40 \text{ max.}$			
Specifications in addition to TIA 568B and ISO/IEC11801					

Step 4) Two Pair or Four Pair

The selection of cables with respect to pair count is straight forward. In general the two cable types are interchangeable with respect to the applications (for 10/100BaseT). The following bullets will provide the selection. Solid cable constructions should be avoided where frequent moving of the cables is expected.

2 pair cabling may be used

- 10/100BaseT applications
- M12-4 “D” coding connectors (see note below)
- 4 circuit. 8-Way modular connectors (RJ45)
- High flex applications
- On machine
- Limited panel space (allows the use of M12 “D” coded connectors)
- Where wire way space is limited. in general the diameter of a 2 pair cable is smaller than a 4 pair cable.
- Field termination is less complicated
- Avoid star quad cable designs (star quad designs have all four conductors twisted). These designs are known to have less noise rejection capabilities.

Use 4 pair cabling

- Back bone and uplink ports.
- Areas where future requirements may require data rates greater than 100BaseT.
- Where the cabling requires support of all “generic applications” such as Voice and Video.
- POE+, or POE mid span

Note: Do not mix 2 pair and 4 pair cables in the same channel unless the un-used pairs are differentially terminated. Do not use 4 pair cables in a 2 pair (4 circuit) connector. See additional rules in step 5.

Example Cable Specification					
Step 1 Channel	Step 2 Cable type	Step 3 EMI Performance	Step 4 2/4 pair	Step 5 M.I.C. severity classifications	Step 6 Additional mech. attributes
<i>Application requires 10/100mb/s</i>	<i>Poor bldg grounds</i>	<i>E3 conducted</i>	<i>M12-4 "D" coded</i>		
<i>Cat6 Class D</i>	<i>UTP</i>	<i>TCL = 73-15 x log (f). 40 max ELTCTL = 50 – 20 x log (f). 40 max.</i>	<i>2 pair</i>		
Specifications in addition to TIA 568B and ISO/IEC11801					

Step 5) MIC Severity Levels

The planner should evaluate each area against the MICE categories and classifications. Doing so helps to determine the cabling requirements and attributes. Most areas within the communications coverage area should be map-able into the MICE table. This step focuses on “M_nI_nC_n” aspects of the environment. For example for cabling on a machine the planner must know the approximate levels of; vibration, dust, liquids, temperatures and chemicals. The M.I.C classifications and categories can then be mapped into the MICE table. The M.I.C classifications then can be placed on the cabling specification. In some cases the classifications may not be known. If this is the case, estimations will be required. For example, if the cabling is to be installed on machines where the vibration is displacement is ≥ 15 , mm and acceleration is $\geq 50 \text{ ms}^{-2}$ then the Mechanical classification is M₃. The same process is used for I and C.

Example Cable Specification					
Step 1 Channel	Step 2 Cable type	Step 3 EMI Performance	Step 4 2/4 pair	Step 5 M.I.C. severity classifications	Step 6 Additional mech. attributes
<i>Application requires 10/100mb/s</i>	<i>Poor bldg grounds</i>	<i>E3 conducted</i>	<i>M12-4 "D" coded sealed required</i>	<i>Installed over steam vessel</i>	
<i>Cat6 Class D</i>	<i>UTP</i>	<i>TCL = 73-15 x log (f). 40 max ELTCTL = 50 – 20 x log (f). 40 max.</i>	<i>2 pair</i>	<i>M₁, I₃, C₃. Liquid condensate (+70°C)</i>	
Specifications in addition to TIA 568B and ISO/IEC11801					

Step 6) Additional Mechanical Attributes (critical)

The additional mechanical attributes need to be considered as these usually require special cable constructions. Missing one of these mechanical requirements will cause premature failure of the cabling components. Therefore thorough consideration is required. For example, if the cable is installed outdoors where exposed to direct sunlight, UV protected cabling is required unless mitigated. The color of the cable may factor into the cable temperature when exposed to direct sunlight. This may then require a high temperature cable design. The following is a list of possible application requirements that have a direct impact on the cabling design;

- 2/4 pair, pair count has a direct bearing on connectors used and vice versa. Generally M12-4 “D” coded connectors require less space than RJ45 sealed connectors.
 - 2 pair cables can be used with 8 circuit connectors such as RJ45 connectors.
 - 4 pair cables cannot be used with 4 circuit connectors such as M12-4 “D” coded connectors.
 - Pair count shall not change within a channel without terminating the un-used pairs. Differential termination is preferred since there is no reference to ground.

- TPE, PVC, FEP and PUR jacket requirements (avoid silicone constructions)
 - Generally TPE is good for oil and weld splatter environments.
 - PVC is an all around material
- Oil Resist II and common cutting fluids per UL 1277 and UL 13
- Sunlight Resistant (UV)
- High Temp > 60 °C (may require channel length de-rating and special materials)
- IP 67 (water) (some PVCs may absorb liquids causing latent failures)
- Weld Splatter
- High Flex (1.5 million minimum)
- Flexible cabling (cord sets and fixed cabling). Stranded cable constructions should be used where frequent moving of the cables either through reconfiguration or vibration is expected.

These additional mechanical requirements are over and above standard cables and will need to be added to the cable specification.

Example Final Cable Specification					
Step 1 Channel	Step 2 EMI Performance	Step 3 Cable type	Step 4 2/4 pair	Step 5 M.I.C. severity classifications	Step 6 Additional mech. attributes
<i>Application requires 10/100mb/s</i>	<i>E3 conducted</i>	<i>Poor bldg grounds</i>	<i>M12-4 "D" coded sealed</i>	<i>Installed over steam vessel</i>	<i>Moisture, rolling C track</i>
<i>Cat6 Class D</i>	<i>TCL = 73-15 x log (f). 40 max ELTCTL = 50 – 20 x log (f). 40 max.</i>	<i>UTP</i>	<i>2 pair</i>	<i>M₁.I₁.C₃. (+70°C)</i>	<i>IP67. UV and High Flex</i>

Specifications in addition to TIA 568B and ISO/IEC11801

This process must be repeated for each environmental area within the communications coverage area.

Glossary

- EFT Electrical Fast Transient, primarily caused by lightning strikes and large electrical loads. EFT is fully described in the IEC 61000 series standards
- ESD Electro Static Discharge, primarily caused by friction of two dissimilar moving surfaces. ESD is fully described in the IEC 61000 series standards.

DeviceNet, DeviceNet Safety, CIP, CIP Motion, CompoNet, CIP Safety and CIP Sync are trademarks of ODVA. EtherNet/IP is a trademark of ControlNet International under license by ODVA. Other trademarks are property of their respective owners.

The ideas, opinions and recommendations expressed herein are intended to describe concepts of the author(s) for the possible use of CIP Networks and do not reflect the ideas, opinions, and recommendation of ODVA per se. Because CIP Networks may be applied in many diverse situations and in conjunction with products and systems from multiple vendors, the reader and those responsible for specifying CIP Networks must determine for themselves its suitability and the suitability of ideas, opinions, and recommendations expressed herein for intended use.

Copyright ©2007 Open DeviceNet Vendor Association, Inc. (ODVA). All rights reserved.
For permission to reproduce excerpts of this material, with appropriate attribution to the author(s), please contact ODVA on:

TEL +1 734-975-8840
FAX +1 734-922-0027
EMAIL odva@odva.org
WEB www.odva.org