

ODVA
2007

CIP Networks Conference
and 12th Annual Meeting

Low Cost Media For DeviceNet

Bob Lounsbury
Principal Engineer
Rockwell Automation

Technical Track

www.odva.org

Abstract

In keeping DeviceNet competitive with other low level networks in the market place, a new media option has been released for DeviceNet. This low cost media provides a whole new approach to installing DeviceNet networks saving both time and money through Insulation Displacement Contact (IDC) technology. This paper will describe the technical merits of the media including topologies and connectorization options. In addition this paper will provide time studies on installation time savings over the traditional DeviceNet media options.

Background

- ▶ DeviceNet Phase I
 - Thick and thin cables
 - Stiff
 - Shielded
 - Three Connectors to choose from
 - Open Style
 - Micro
 - Mini

- ▶ Difficult to wire
- ▶ Many startup problems due to miss-wiring.

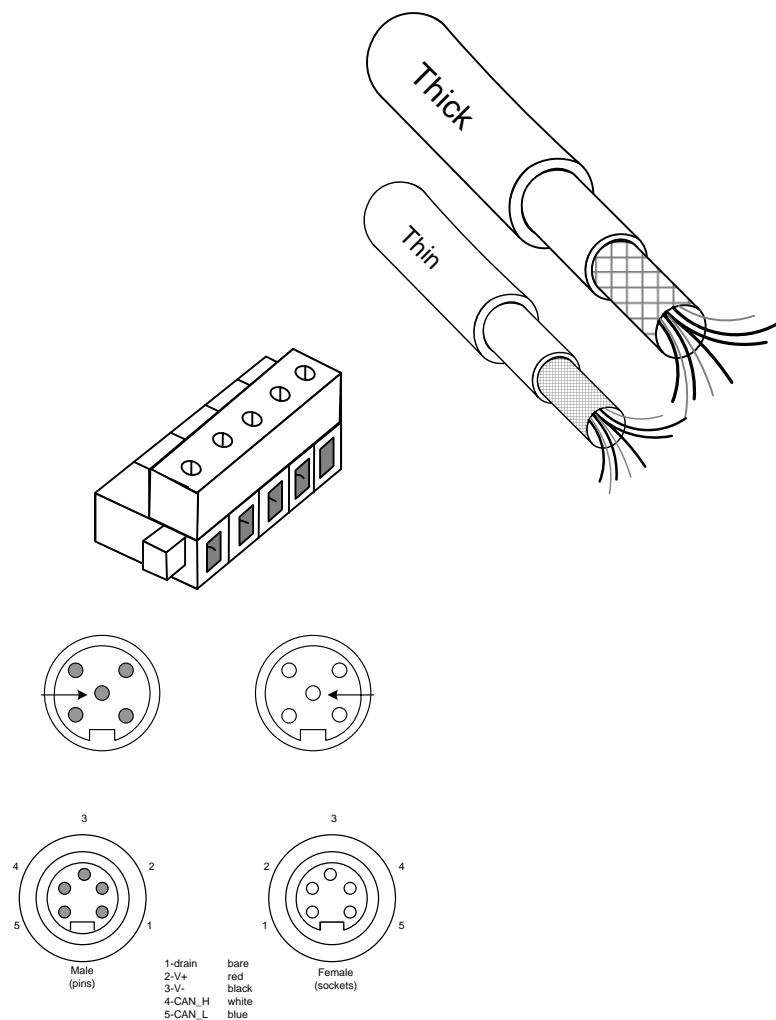

- ▶ DeviceNet Phase II
 - New Media
 - Flat Cable Type I
 - IDC IP65/67 Sealed modules
 - » Support Open style and
 - » Micro connectivity
- ▶ Cost savings in installation time
- ▶ Customer startup much easier and trouble free

Flat Type I

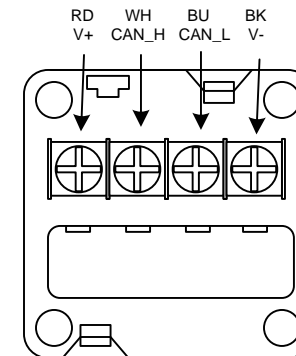
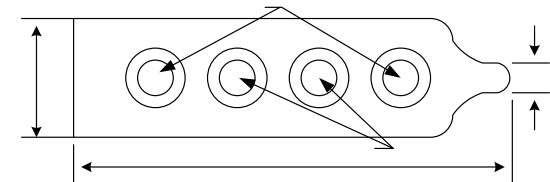

Open-Style

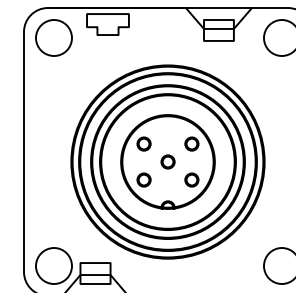

Micro

Flat Type II

▶ Goal

- Inexpensive
- IP 20/54
- Flexible media
- Installs with standard pocket tools
- Fast, under 3 minutes

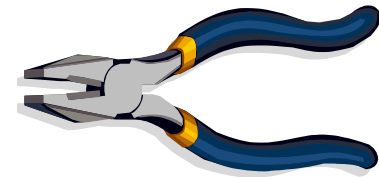

CompoNet Media For DeviceNet

- ▶ Media was redesigned to meet the basic requirements of DeviceNet
 - Impedance
 - Low capacitance
 - Integral Capacitor in Tap
- ▶ Based on the redesigned cable the theoretical trunk and drop lengths were calculated
- ▶ Calculations assume 6 meter drop cables.

Table 1 Initial Theoretical Trunk Lengths

Data rate	ODVA specification (Thick/Flat)	Type II theoretical trunk length	Cumulative drop length	Limiting parameter
125Kb/s	500/420 Meters	350 meters	159meters	Amplitude margin
250Kb/s	250/200 Meters	150 meters	78 meters	Amplitude margin
500Kb/s	100/75 Meters	55 meters	39 meters	Reflected delay margin

Connectors

- ▶ Installation speed required IDC technology for connections to the trunk
- ▶ The contacts and cable entry was designed to support DeviceNet thin conductors 24/22 gauge
- ▶ The Connector system consists of an IDC tap with integral 0.2uf capacitor and a IDC plug.

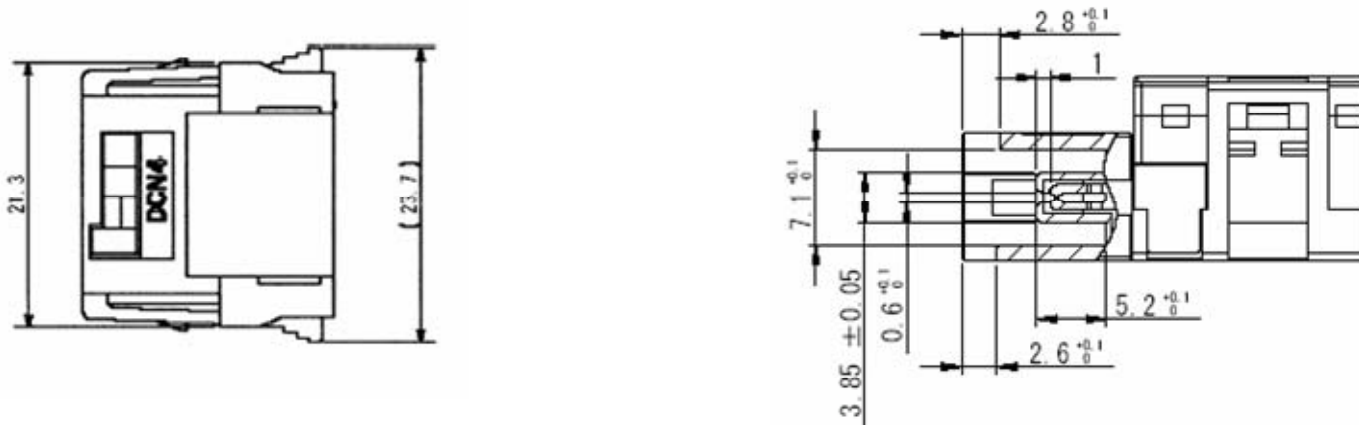

The Ideal DeviceNet Cable

- ▶ An ideal cable for DeviceNet would have;
 - 120 Ohms
 - High Velocity $V_p > 74\%$
 - Low Capacitance
 - Low Insertion Loss
- ▶ Due to the CAN limitations, Velocity and Common Mode Offsets, all new cables must be evaluated for transmission performance and IR drop.
- ▶ The cable was tested and found to be within the required 120 Ohms +/- 10% 0.100MHZ to 0.500MHZ
- ▶ Velocity was found to be constant with a PVC construction < 62%
- ▶ Attenuation was

Transmission Performance

- ▶ The cable transmission parameters were tested and found to be acceptable for use in a DeviceNet network

Parameter	100KHz	125KHz	250KHz	500KHz	1MHz
100 ft sample					
Zo	126	127.5	129.8	131.6	132.47
VP	54.8	55	57.5	59.7	61.4
Atten Calc	0.12235	0.14	0.21809	0.35592	0.631
Atten Mea	0.1025	0.1378	0.25	0.4223	0.7185
CO	14.81	14.37	13.658	12.967	12.485
10 ft sample					
Zo	123	124.6	129.68	132	134
VP	52	54.6	56.3	58.8	61
Atten Calc	0.067	0.096	0.19229	0.3472	0.531
Atten Mea	0.10383	0.13563	0.232	0.4211	0.71835
CO	15.8	15	13.94	12.9	12.5

Cable DCR

- ▶ The cable V+ and V- DCR has a direct impact on the network Common mode offset
- ▶ The CAN_H and CAN_L DCR will have a direct impact on the signal attenuation.
- ▶ The DCR was measured and also calculated based on the copper cross-sectional area

Conductor	Spool 3	New Spool	Calculated based on copper area.
Black	2.343	2.260	2.2603
Red	2.345	2.263	2.2603
White	3.527	3.412	3.3876
Blue	3.526	3.401	3.3876

Correlation between the measured and calculated was possible

Predicted Topology

- ▶ Based on the transmission performance of the media and the cable DCR, the trunk and drop limits can be determined including margins.

Data rate	Amplitude margin %	Delay margin %	Reflection delay margin %	Trunk (meters)	Drop (meters)
125kbps	1.04	25.5	8.25	325	156
250kbps	1.98	10.1	1.40	175	50
500kbps	2.7	6.99	1.53	65	25

The calculations show that the cable is amplitude and reflection delay limited.

Reflection delay has two components

- Cable delay
- Reflection amplitude

Worst Case Topologies

- ▶ Three transmission limits limit cabling length and drop budget
 - Delay, delay is a function of the cable function + a fixed delay of 604ns
 - Reflection Margin, is a function of the cabling attenuation, cabling delay and magnitude of the reflections.
 - Amplitude Margin, is a function of cable attenuation.

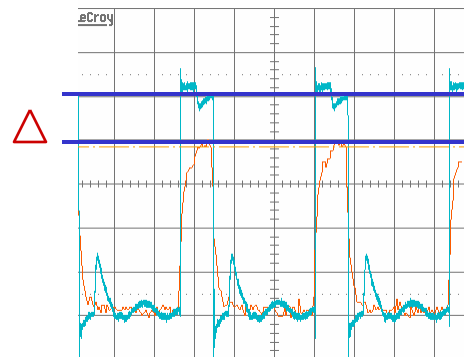
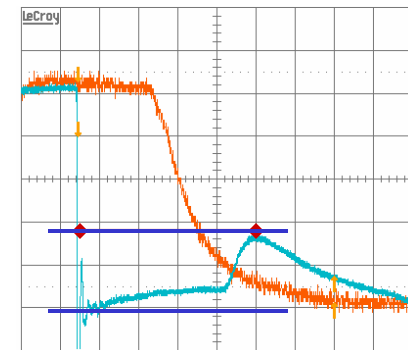
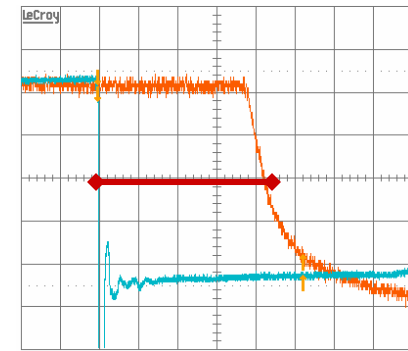

How Parameters affect Network

► Delay Margin

- Delay is caused by propagation of signals through the cable. Due to the dielectric, the propagation is less than that of free space.
- The worse case delay will occur in a cabling system that has the max length trunk including drop cables

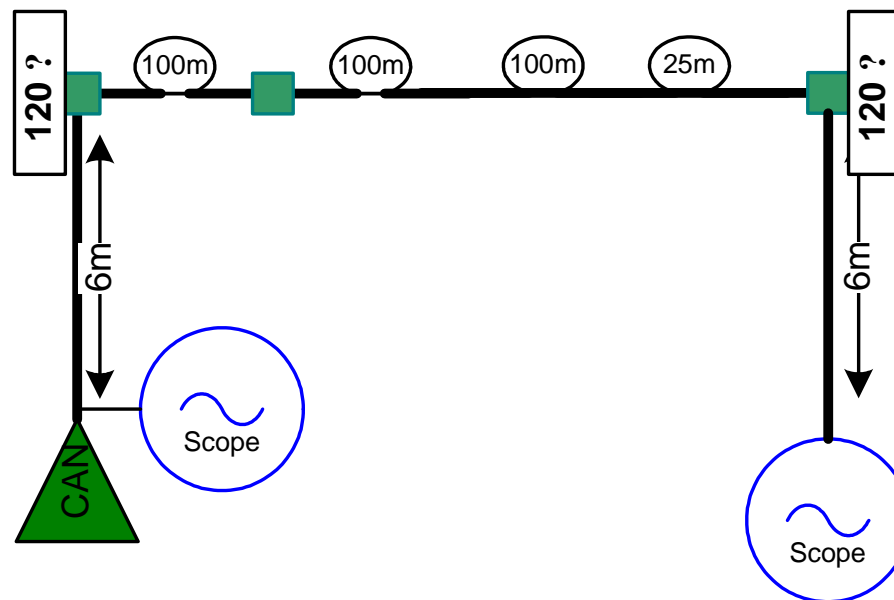

Reflection Margin

- ▶ Caused by natural reflections in the network. They are a function of the miss-matches caused by the drop cables and nodes.
- ▶ To Maximize reflections the following topology is needed, Node input resistance is high, capacitance is high, maximum drop and nodes lumped together.

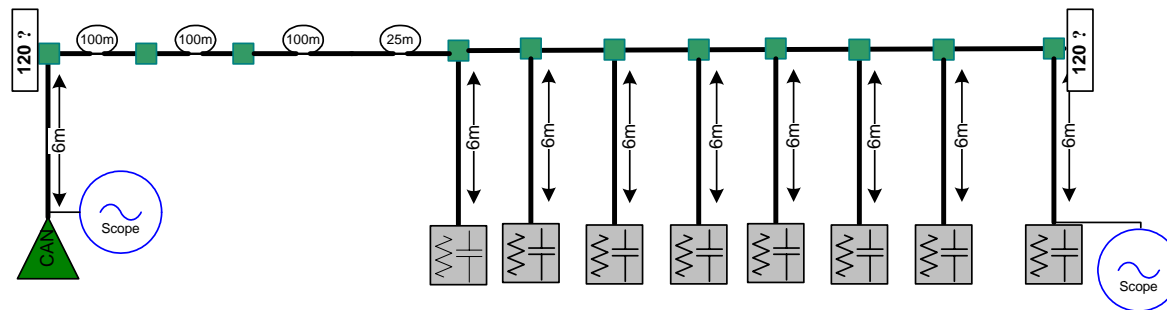

Amplitude Margin

- ▶ Attenuation is caused by losses in the system. The largest component is the trunk cable attenuation. The loading of parallel node input resistance causes additional attenuation.
- ▶ Worse case amplitude margin occurs when the node input resistance is at minimum and capacitance is maximum and max trunk cable length. Placement of nodes is not important in this configuration.

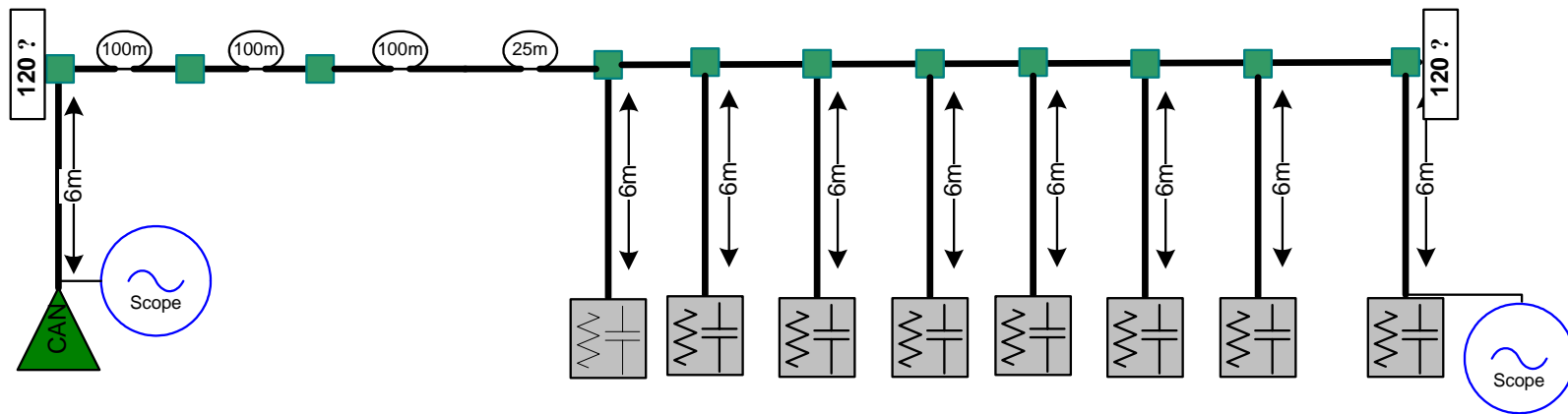

Summary of Measurements and Calculations

- ▶ The calculations produced conservative results in most cases.
- ▶ The measured values were made using lumped elements in place of actual devices.
- ▶ The final analysis was performed using a fully loaded network with actual DeviceNet nodes.

Data Rate	Trunk Length		Drop Cable	
	Predicted	Measured	Predicted	Measured
125kbps	325	319	156	156
250kbps	175	212	50	48
500kbps	65	75m	25	25

Topology Verification

- ▶ A test stand equipped with 64 nodes and CompoNet cabling system was used to verify the topology limits that were previously calculated and simulated.



Test Stand Front

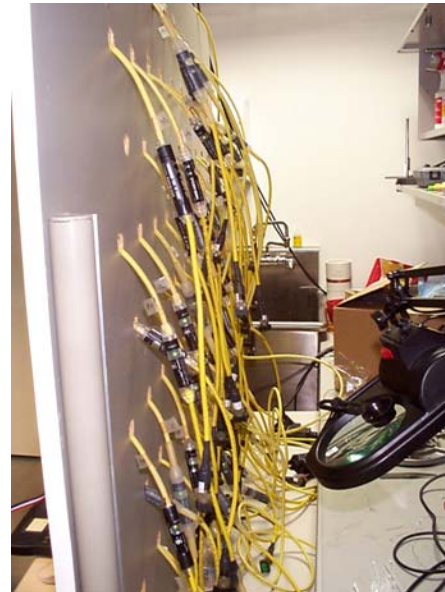

Test Stand Back

Test Procedure

- ▶ Study performed at all three data rates
- ▶ Worse case configurations were assembled for each limiting parameter (Delay, Reflection Delay and amplitude)
- ▶ Maximum number of nodes (64)
- ▶ Maximum trunk length and drop cable
- ▶ Worse case placement of nodes in network
- ▶ Each configuration was designed to determine the maximum reliable trunk length base on BER and Signal quality
- ▶ Worse case Addressing of nodes was determine and used

Examples of Worse Case Configurations

- ▶ Configuration 1 produces max reflections
- ▶ Configuration 2 produces max delay
- ▶ Both configurations produce max attenuation

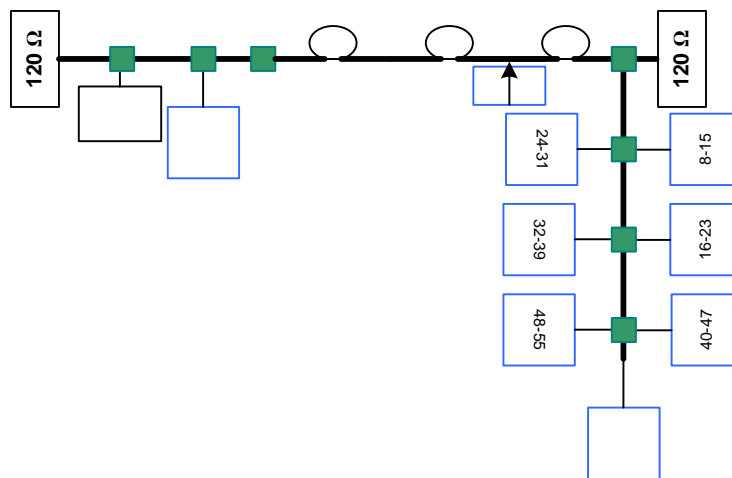

Configuration 1

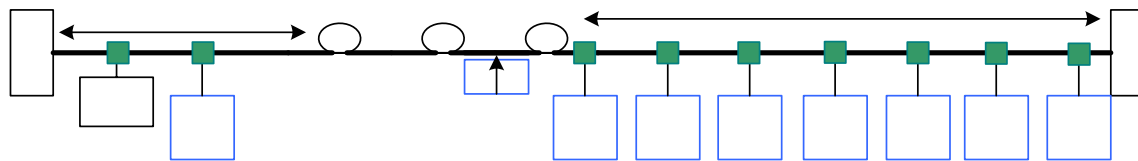

Configuration 2



Summary of Measurements and Node Testing

- ▶ Node testing produced the most conservative results.
- ▶ This is primarily due to the added common mode offset and the dynamics of the transceiver/controller.

Data Rate	Trunk Length		Drop Cable	
	Measured	Node Test	Measured	Node Tests
125kbps	319	263	156	134
250kbps	212	157	48	52
500kbps	75m	87m	25m	36m

- ▶ Final Trunk and Drop Lengths

Data Rate	Trunk Length	Drop Length
125Kbps	165 meters	135 meters
250kbps	150 meters	48 meters
500kbps	75 meters	35 meters

Cable Length Based on Ampacity of Cabling

- ▶ Graph represents the network length versus network current
- ▶ Based on V+ and V- DCR
- ▶ Same analysis as other DeviceNet cabling variants
- ▶ Assumes all nodes are at farthest end from the network power supply
- ▶ Graph A, at 20 degrees C
- ▶ Graph B, at 80 degrees C

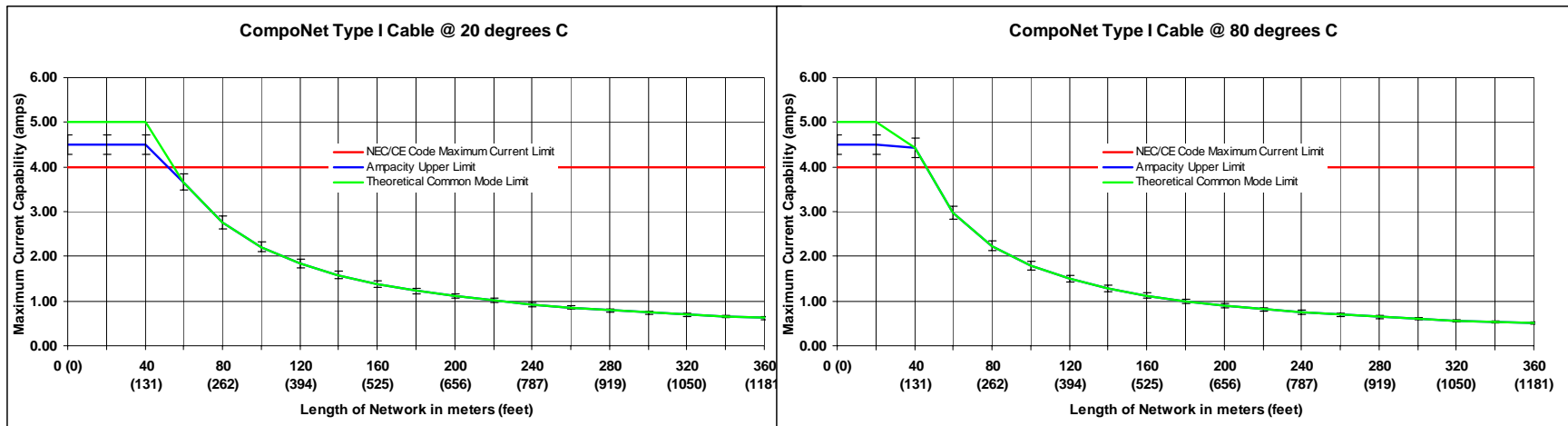

Graph A

Graph B

Installation Time Studies

- ▶ Installation time is critical in reducing the total cost of installation and ownership
- ▶ The installation time for CompoNet media was compared to Flat Type I media.
 - Flat Type I takes approximately three to ten minutes (depending on mounting requirements of the taps)
 - CompoNet media takes less than 1 minute to terminate (both ends, tap and drop)
- ▶ Installation time savings of 2-9 minutes per connection to the trunk