

ODVA
2007

CIP Networks Conference
and 12th Annual Meeting

Techniques for Network Analysis and Troubleshooting

Bob Lounsbury
Principal Engineer
Rockwell Automation
EtherNet/IP Physical Layer JSIG Chair

Technical Track

www.odva.org

Abstract

Network down time is costly to the customer base. EtherNet/IP cabling includes an M12-4 "D" coded connector that uses 2 pair cabling. This presents problems for Standard off the shelf testers. Because EtherNet/IP is a control network, network acceptance testing is very important. Further quickly determining a cable fault is key in returning a failed network back to an operational state. Now that Ethernet/IP has been in the market place for several years, it has gained the attention of the network test tool companies. This paper will cover network testing requirements, testing problems and solutions for field test equipment and networks. It will provide guidance on selecting tools and test criteria required to properly commission a network. For example testing 2 pair cables requires a special adaptation of the standard off the shelf testers. The testers must be capable of testing NEXT, FEXT, RL, Attenuation and now TCL and ELTCTL for all cable types.

Network Planner

- ▶ The network planner is responsible for specifying the requirements for;
 - Verification and
 - Certification
- ▶ Verification results and deviations are reported to the Planner and Certification personnel
- ▶ Certification personnel reviews documentation from planner and performs required certification tests and produces a complete acceptance report



Importance of network Verification and Certification

- ▶ Verification is typically carried out by the Installer
- ▶ Certification is typically carried out by a third party
- ▶ Both are important in reducing startup time and cost





Difference between Verification and Certification

▶ Verification

- Carried out by Installer
- Means for installer to verify work on the go
- Input to Certification process
- Inexpensive tools
- Basic tests
- Can be used for basic troubleshooting

▶ Certification

- Carried out by 3rd party
- In-depth testing
- Certifies network can support application
- Expensive elaborate tools
- Requires training
- Requires understanding of parameters
- Can be used in the troubleshooting process

Installer Verification Tool Belt

- ▶ Verification and troubleshooting tools
 - Cable tester
 - Fiber fault finder
 - DVM
- ▶ Tools provide effective means to verify and troubleshoot networks.

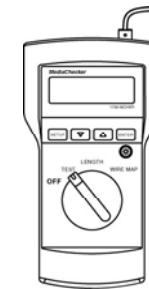

31195-M

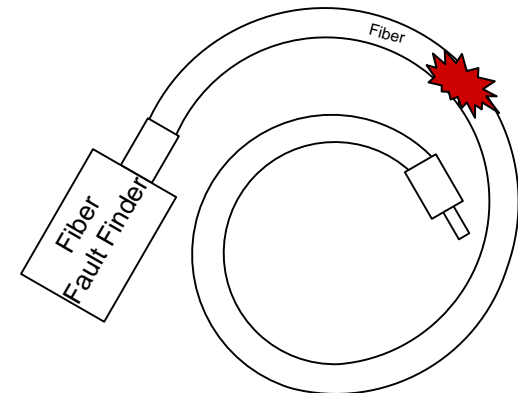
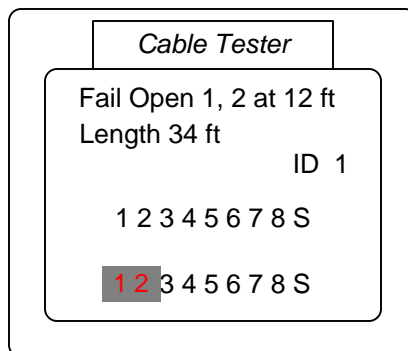

Network Verification

► Network Verification checks for;

- Correct wiring (wire map)
- Channel length
- proper termination
- Faults to ground
- Uses simple test tools
 - Requires Minimal training
 - Same tool can be used for troubleshooting

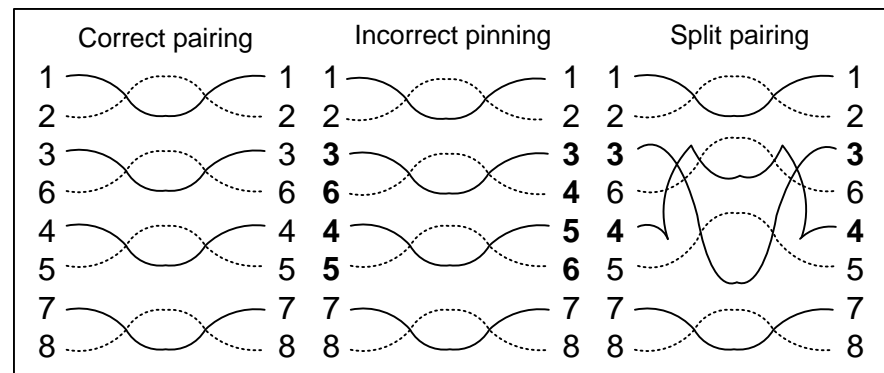
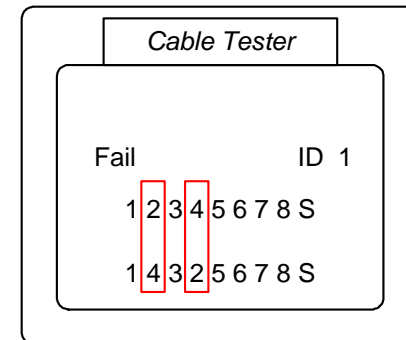

Verification

- ▶ Other Verification Tests using a DVM
 - Grounding and Bonding
 - Visual
 - Measurements
 - » Connections < .005 Ohms
 - » Conductors < 1 Ohm
 - Shorts to ground
 - Proper Shield termination

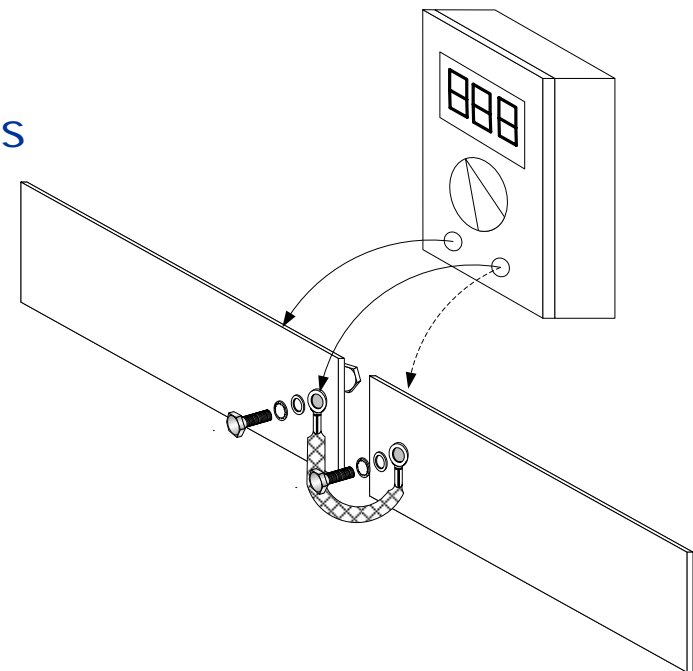
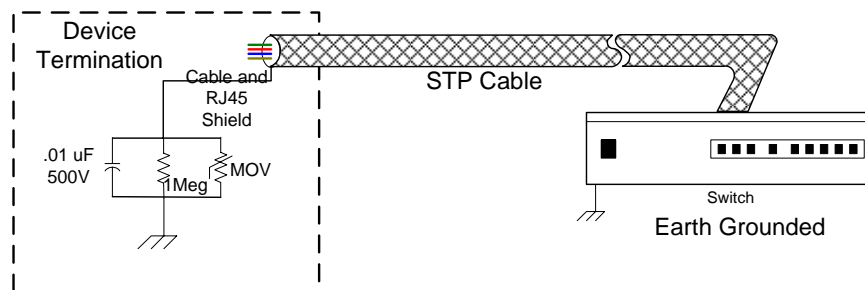

Measurement Points

- ▶ Verification and Certification of;
 - Channels
 - Links (P-Links)
 - Cords/Jumpers

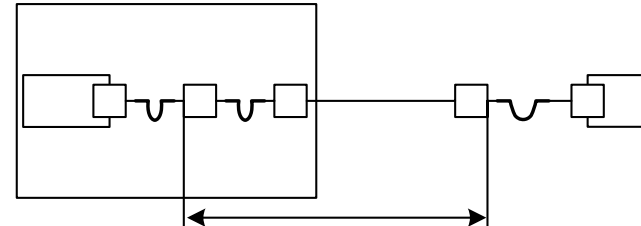
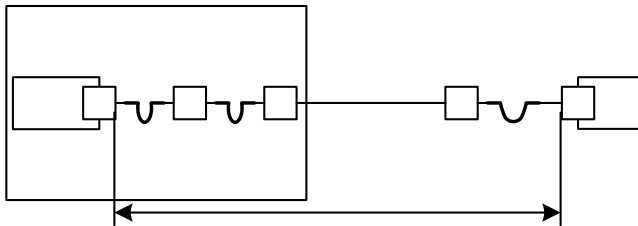

Network Certification

- ▶ Provides a Benchmark of the network for future use
- ▶ Network Certification assures that the cabling system can support the intended application
- ▶ Unbiased evaluation
- ▶ Usually is accompanied with a detailed report
- ▶ Can be used in a court of law
- ▶ Requires training and understanding of Generic Cabling systems and important parameters

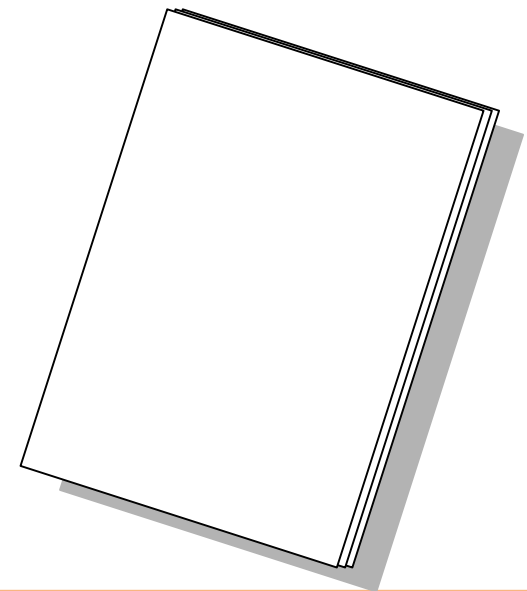

Certification

► Network certification tools

- Four types of testers
 - Levels I – IV depending on bandwidth of cabling system and accuracy
 - Can be used for troubleshooting and verification
- Calibrated and traceable to standards (NIST and others)
- Capable of producing swept frequency measurements of the following Main cable parameters
 - Channel and permanent link length
 - Wire Map
 - Faults in cabling
 - Return Loss
 - Impedance
 - Attenuation
 - NEXT/FEXT
 - DC resistance
 - Delay and Delay Skew
 - ACR
- Calculated main measurements
 - ELFEXT
 - Power Sum ELFEXT
 - Power Sum NEXT and
 - Power SUM ACR

NEXT (fail)

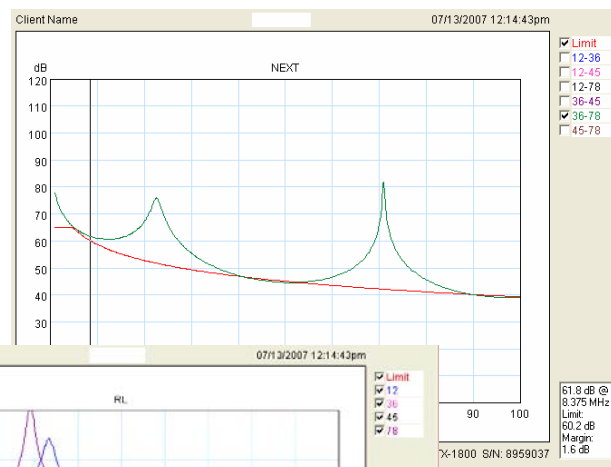

Return Loss (pass)

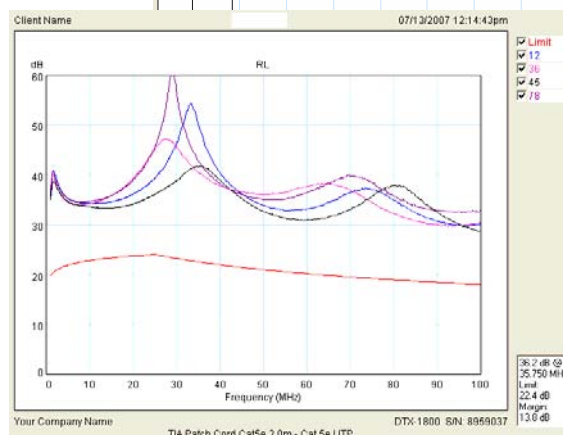

M12-4 D Coding Support

- ▶ M12-4 D Coding 2 pair connector support
 - Certification testers always perform wire map testing first.
 - Early version testers stop if the wire map is incorrect
 - Newer breed of testers support 2 pair and continue testing.
 - Some certification tester manufactures are providing test heads with M12-4 D Coding interfaces.

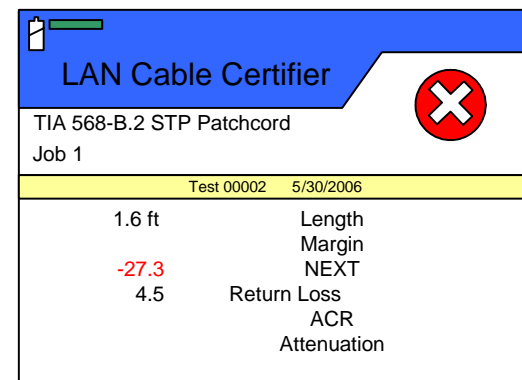

LAN Cable Certifier	
TIA 568-B.2 STP Patchcord	
Job 1	
Test 00002 5/30/2006	
1.6 ft	Length
-27.3	Margin
4.5	Return Loss
	ACR
	Attenuation



What to Look for in Cable Certifiers

- ▶ 2 pair support including M12-4 D coding connectors
- ▶ Patch cord support for lengths **longer** than 10m (33 ft)
- ▶ Ability to test to Category 6 minimum.
- ▶ Fiber support (if your plans are to install fiber)
- ▶ TDR capability to quickly locate faults

Critical Measurements

- ▶ Some measurements are critical for noise immunity;
 - Important but not supported by field testers is; TCL, ELTCTL and Coupling Attenuation
 - NEXT, Near End Cross Talk is noise from the transmitter that is normally canceled out in the receiver. Excessive Crosstalk will cause S/N problems, thus High error rates.
 - NEXT is the most common failure, especially in field terminated cabling.
 - Poor Return Loss also impacts S/N and is worse if NEXT is high.
 - Attenuation can be abnormally high due to stranded cable constructions (X 1.2 – X 1.5), long cordsets and high temperatures. Also impacts S/N

Terminations and Performance

- ▶ Termination techniques can either make or break a channel or P-Link;
 - Separation the pairs at the back end of the connector by more than 0.25" can cause RL failures
 - Separation of the pairs by more than 0.5" will also impact the NEXT performance.
 - Separation of the pairs in the center of the cable (bending) RL may fail (3/16")
 - Over tightening the connector shell will cause RL failures

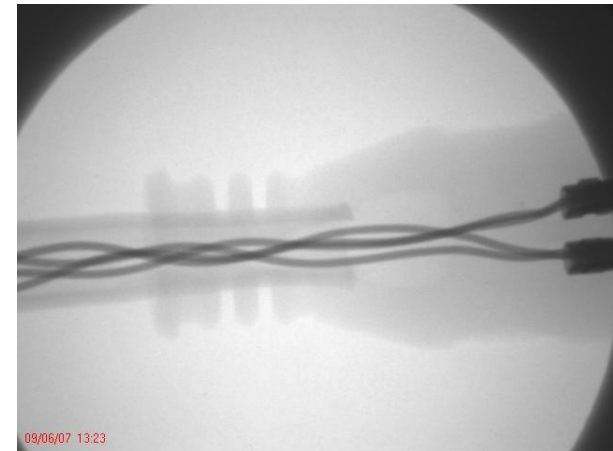
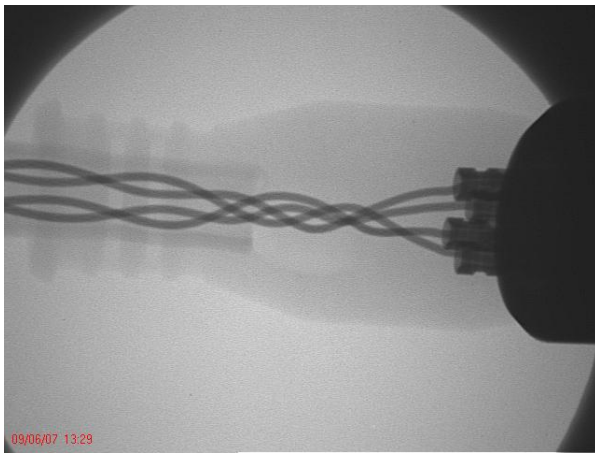

Measurements Anomalies

- ▶ Understanding measurements;
 - If the certification or verification process indicates a problem further diagnostics will be required to locate the fault
 - Locating shorts, opens, split pairs, miss pinned connectors are very straight forward.
 - TDR can be used to locate shorts and opens in middle of the cable
 - Other failures are normally limited to connector termination errors
 - Transmission faults (RL, NEXT ELFEXT etc) are more difficult to find. For example a RL fault. A TDR may indicate a fault in the center of the cable, however this may be caused by the connectors.